



85V 3.3mΩ N-Ch Power MOSFET

Features

- Ultra-low $R_{DS(ON)}$
- Low Gate Charge
- High Current Capability
- 100% UIS Tested, 100% R_g Tested

Applications

- Power Management in Telecom., Industrial Automation, CE
- Current Switching in DC/DC & AC/DC (SR) Sub-systems
- Motor Driving in Power Tool, E-vehicle, Robotics

Product Summary

Parameter	Typ.	Unit
V_{DS}	85	V
$V_{GS(th)}$	2.8	V
I_D (@ $V_{GS} = 10V$)	146	A
$R_{DS(ON)}$ (@ $V_{GS} = 10V$)	3.3	mΩ

TO220-3L Top View

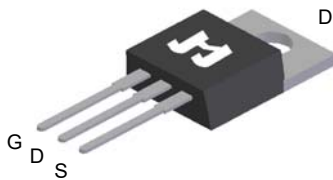

TO263-3L Top View

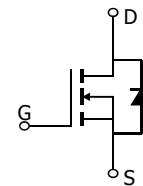
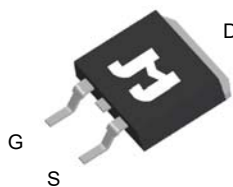

Ordering information

Device	Package	# of Pins	Marking	MSL	T_J (°C)	Media	Quantity (pcs)
JMSH0804BC-U	TO220-3L	3	SH0804B	N/A	-55 to 150	Tube	50
JMSH0804BE-13	TO263-3L	3	SH0804B	3	-55 to 150	13-inch Reel	800

Absolute Maximum Ratings (@ $T_A = 25^\circ\text{C}$ unless otherwise specified)

Parameter	Symbol	Value	Unit
Drain-to-Source Voltage	V_{DS}	85	V
Gate-to-Source Voltage	V_{GS}	± 20	V
Continuous Drain Current	I_D	$T_C = 25^\circ\text{C}$	146
		$T_C = 70^\circ\text{C}$	117
Pulsed Drain Current	I_{DM}	600	A
Avalanche Current	I_{AS}	60	A
Avalanche Energy (@ $L = 0.1\text{mH}$)	E_{AS}	180	mJ
Power Dissipation	P_D	$T_C = 25^\circ\text{C}$	156
		$T_C = 70^\circ\text{C}$	100
Junction & Storage Temperature Range	T_J, T_{STG}	-55 to 150	°C

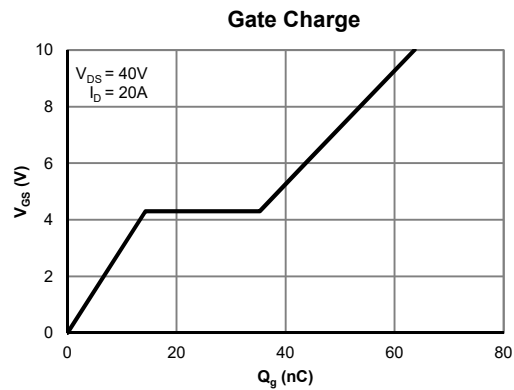
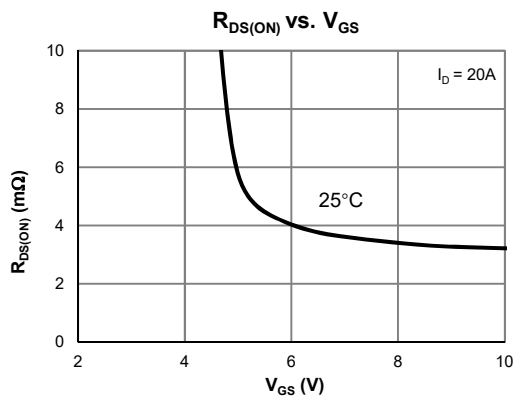



Electrical Characteristics (@ $T_j = 25^\circ\text{C}$ unless otherwise specified)

Parameter	Symbol	Conditions	Min.	Typ.	Max.	Unit
STATIC PARAMETERS						
Drain-Source Breakdown Voltage	$V_{(BR)DSS}$	$I_D = 250\mu\text{A}, V_{GS} = 0\text{V}$	85			V
Zero Gate Voltage Drain Current	I_{DSS}	$V_{DS} = 68\text{V}, V_{GS} = 0\text{V}$ $T_j = 55^\circ\text{C}$			1 5	μA
Gate-Body Leakage Current	I_{GSS}	$V_{DS} = 0\text{V}, V_{GS} = \pm 20\text{V}$			± 100	nA
Gate Threshold Voltage	$V_{GS(th)}$	$V_{DS} = V_{GS}, I_D = 250\mu\text{A}$	2.0	2.8	4.0	V
Static Drain-Source ON-Resistance	$R_{DS(ON)}$	$V_{GS} = 10\text{V}, I_D = 20\text{A}$		3.3	4.0	m Ω
Forward Transconductance	g_{FS}	$V_{DS} = 5\text{V}, I_D = 20\text{A}$		42		S
Diode Forward Voltage	V_{SD}	$I_S = 1\text{A}, V_{GS} = 0\text{V}$		0.7	1.0	V
Diode Continuous Current	I_S	$T_C = 25^\circ\text{C}$			156	A

DYNAMIC PARAMETERS

Input Capacitance	C_{iss}	$V_{GS} = 0\text{V}, V_{DS} = 40\text{V}, f = 1\text{MHz}$		4060		pF
Output Capacitance	C_{oss}			1341		pF
Reverse Transfer Capacitance	C_{rss}			9		pF
Gate Resistance	R_g	$V_{GS} = 0\text{V}, V_{DS} = 0\text{V}, f = 1\text{MHz}$		1.5		Ω

SWITCHING PARAMETERS

Total Gate Charge (@ $V_{GS} = 10\text{V}$)	Q_g	$V_{GS} = 0 \text{ to } 10\text{V}, V_{DS} = 40\text{V}, I_D = 20\text{A}$		63		nC
Total Gate Charge (@ $V_{GS} = 6\text{V}$)	Q_g			43		nC
Gate Source Charge	Q_{gs}			14		nC
Gate Drain Charge	Q_{gd}			21		nC
Turn-On DelayTime	$t_{D(on)}$	$V_{GS} = 10\text{V}, V_{DS} = 40\text{V}$ $R_L = 2.0\Omega, R_{GEN} = 3\Omega$		17		ns
Turn-On Rise Time	t_r			38		ns
Turn-Off DelayTime	$t_{D(off)}$			65		ns
Turn-Off Fall Time	t_f			43		ns
Body Diode Reverse Recovery Time	t_{rr}		$I_F = 20\text{A}, di_F/dt = 100\text{A}/\mu\text{s}$		65	
Body Diode Reverse Recovery Charge	Q_{rr}	$I_F = 20\text{A}, di_F/dt = 100\text{A}/\mu\text{s}$		144		nC

Thermal Performance

Parameter	Symbol	Typ.	Max.	Unit
Thermal Resistance, Junction-to-Ambient	$R_{\theta JA}$	45	55	$^\circ\text{C}/\text{W}$
Thermal Resistance, Junction-to-Case	$R_{\theta JC}$	0.65	0.8	$^\circ\text{C}/\text{W}$

Typical Electrical & Thermal Characteristics

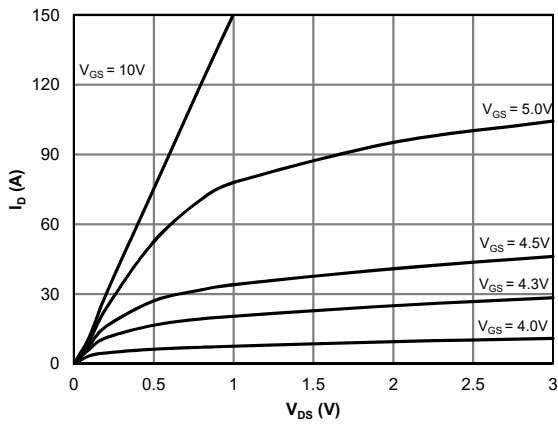

Figure 1: Saturation Characteristics

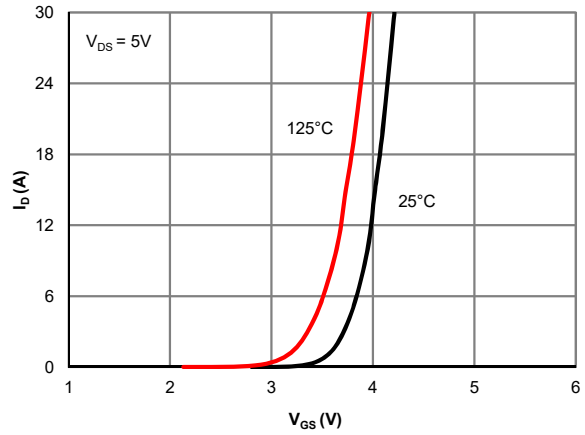

Figure 2: Transfer Characteristics

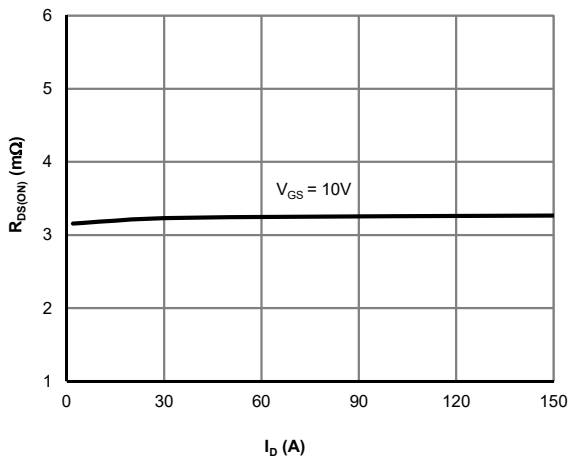

Figure 3: $R_{DS(ON)}$ vs. Drain Current

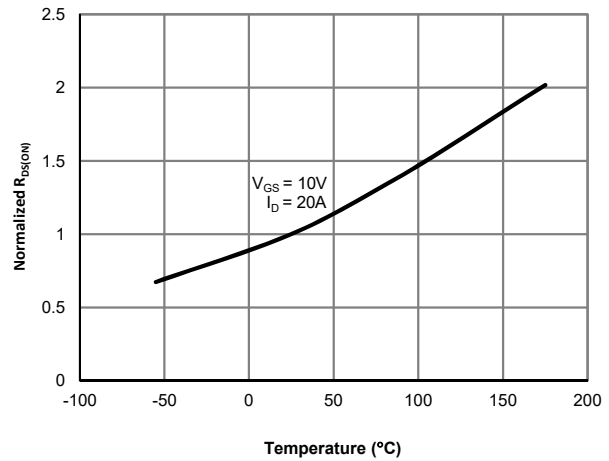

Figure 4: $R_{DS(ON)}$ vs. Junction Temperature

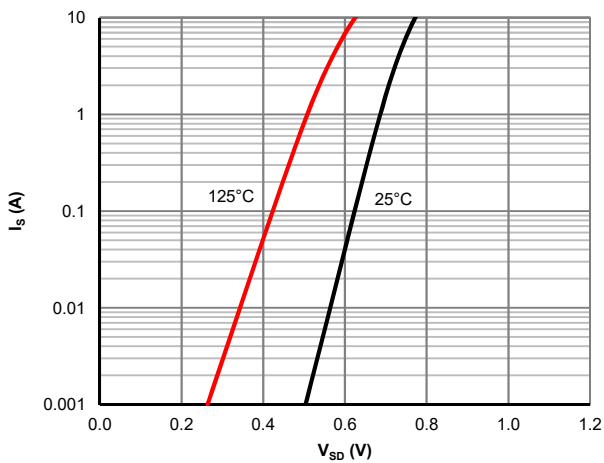

Figure 5: Body-Diode Characteristics

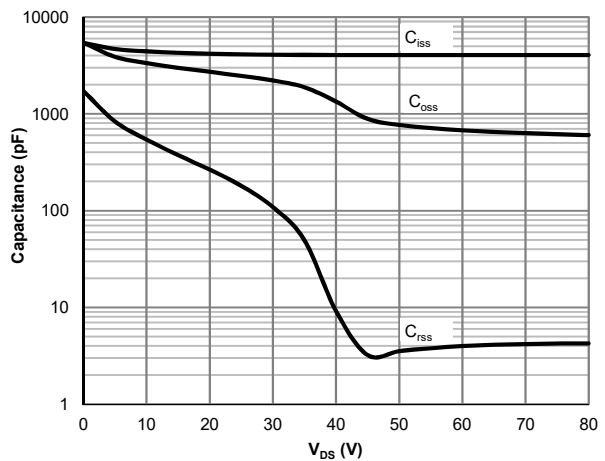

Figure 6: Capacitance Characteristics

Typical Electrical & Thermal Characteristics

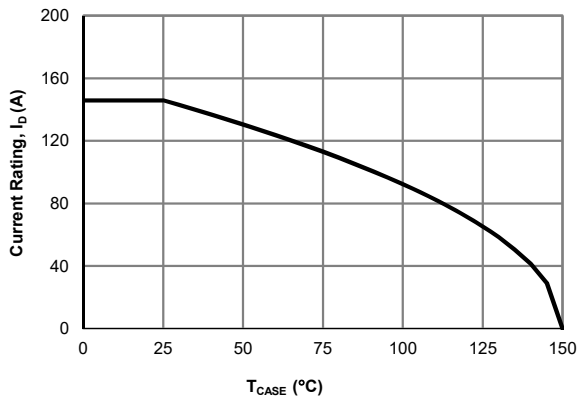

Figure 7: Current De-rating

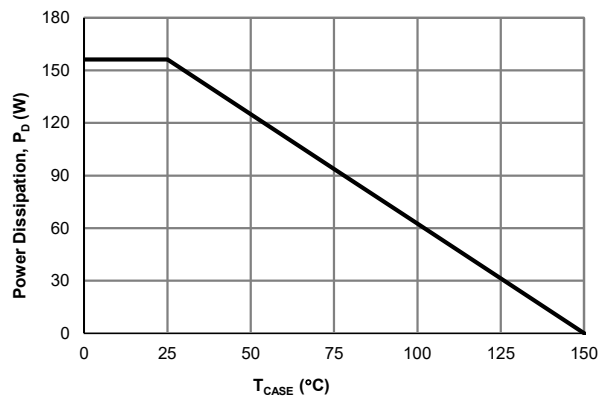

Figure 8: Power De-rating

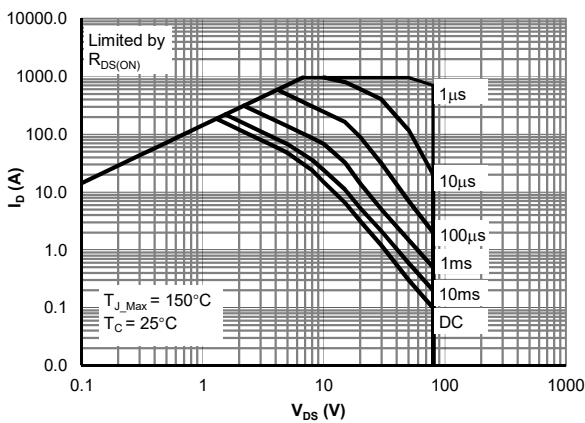

Figure 9: Maximum Safe Operating Area

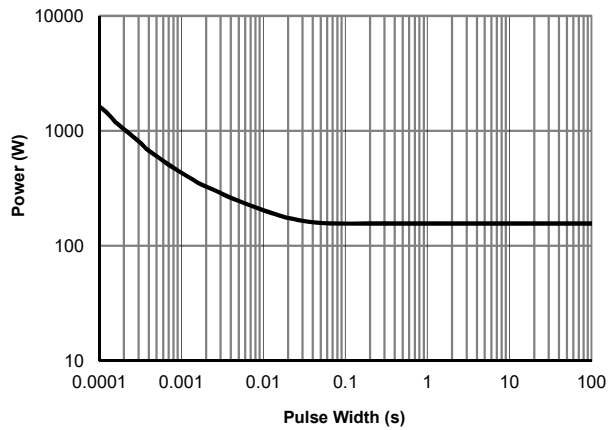

Figure 10: Single Pulse Power Rating, Junction-to-Case

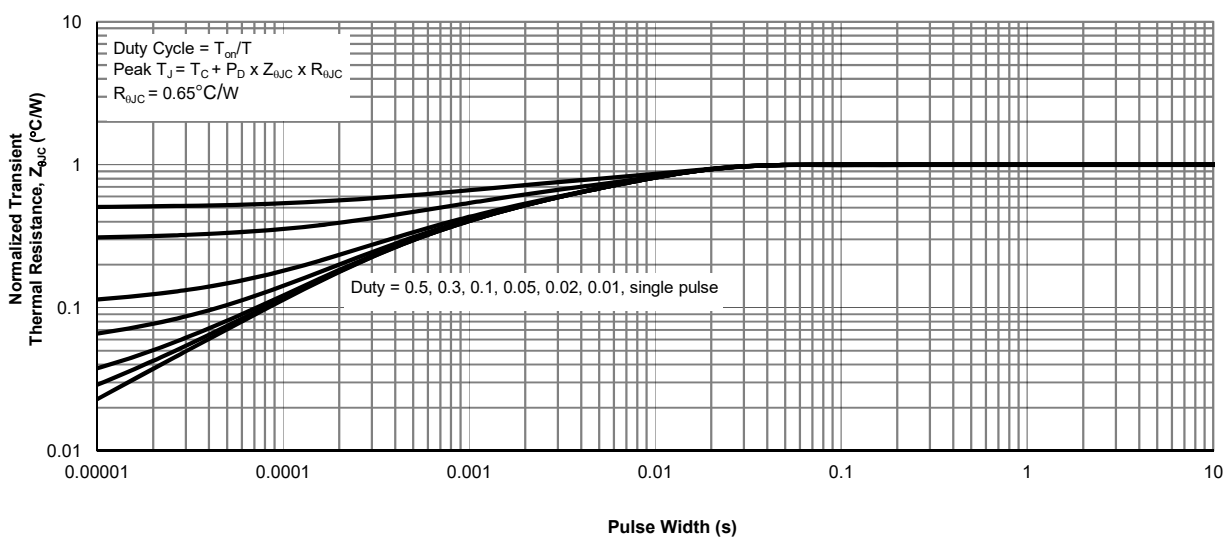
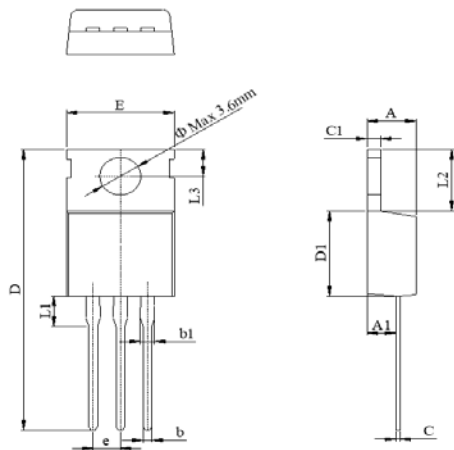

Figure 11: Normalized Maximum Transient Thermal Impedance



TO220-3L Package Information (All units in mm)

Package Outline



DIM.	MILLIMETER		
	MIN.	NOM.	MAX.
A	4.37		4.70
A1	2.20		3.00
b	0.70		0.95
b1	1.14		1.70
C	0.45		0.60
C1	1.23		1.40
D	28.00		29.80
D1	8.80		9.90
E	9.70		10.50
L1			3.80
L2	6.25		6.90
L3	2.40		3.00
e		2.54 BSC	

TO263-3L Package Information (all units in mm)

Package Outline

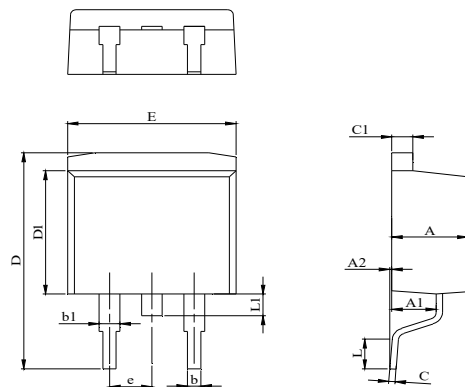

DIM.	MILLIMETER		
	MIN.	NOM.	MAX.
A	4.37		4.77
A1	2.30		2.89
A2	0.00	0.10	0.25
b	0.70		0.96
b1	1.17		1.47
C	0.30		0.55
C1	1.22		1.42
D	14.10		15.80
D1	8.50		9.60
E	9.86		10.36
L	2.00		2.60
L1			1.75
e		2.54	

Recommended Footprint

