



DESCRIPTION:

With high ability to withstand the shock loading of large current, JCTx55 SCRs provide high dv/dt rate with strong resistance to electromagnetic interference. They are especially recommended for use on solid state relay, motorcycle, power charger, T-tools etc. From all three terminals to external heatsink, JCTx55Z provides a rated insulation voltage of 2500 V_{RMS}, complying with UL standards (File ref: E252906).

MAIN FEATURES

Symbol	Value	Symbol
V _{DRM} / V _{R_{RRM}}	600/800	V
I _{T(RMS)}	55	A
I _{GT}	10-50	mA

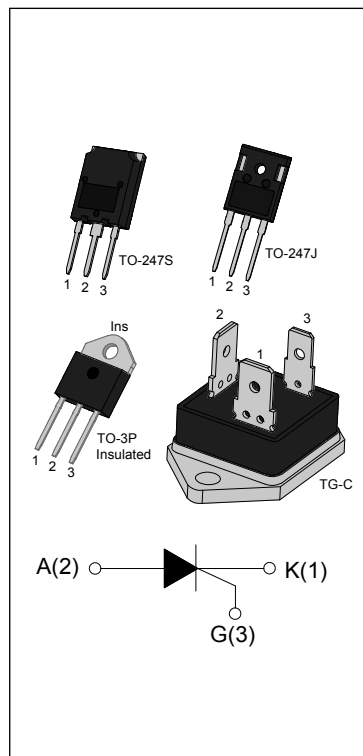

ABSOLUTE MAXIMUM RATINGS

Parameter	Symbol	Value	Unit
Storage junction temperature range	T _{stg}	-40-150	°C
Operating junction temperature range	T _j	-40-125	°C
Repetitive peak off-state voltage	V _{DRM}	600/800	V
Repetitive peak reverse voltage	V _{R_{RRM}}	600/800	V
RMS on-state current	TO-3P Ins (T _c =70°C)	55	A
	TO-247S/TO-247J (T _c =75°C)		
	TG-C (T _c =73°C)		
Non repetitive surge peak on-state current (t _p =10ms)	I _{TSM}	520	A
I ² t value for fusing (t _p =10ms)	I ² t	1350	A ² s
Critical rate of rise of on-state current (I _G =2×I _{GT})	di/dt	150	A/μs

Peak gate current	I_{GM}	5	A
Peak gate power	P_{GM}	10	W
Average gate power dissipation ($T_j=125^\circ\text{C}$)	$P_{G(AV)}$	1	W

ELECTRICAL CHARACTERISTICS ($T_j=25^\circ\text{C}$ unless otherwise specified)

Symbol	Test Condition	Value			Unit
		MIN.	TYP.	MAX.	
I_{GT}	$V_D=12\text{V } R_L=33\Omega$	10	15	50	mA
V_{GT}		-	-	1.5	V
V_{GD}	$V_D=V_{DRM} T_j=125^\circ\text{C } R_L=3.3\text{K}\Omega$	0.2	-	-	V
I_L	$I_G=1.2I_{GT}$	-	-	100	mA
I_H	$I_T=500\text{mA}$	-	-	80	mA
dV/dt	$V_D=2/3V_{DRM} T_j=125^\circ\text{C}$ Gate Open	700	-	-	V/ μs

STATIC CHARACTERISTICS

Symbol	Parameter	Value(MAX)	Unit	
V_{TM}	$I_{TM}=80\text{A } t_p=380\mu\text{s}$	$T_c=25^\circ\text{C}$	1.6	V
I_{DRM}	$V_D=V_{DRM} V_R=V_{RRM}$	$T_c=25^\circ\text{C}$	10	μA
I_{RRM}		$T_c=125^\circ\text{C}$	6	mA

THERMAL RESISTANCES

Symbol	Parameter	Value	Unit	
$R_{th(j-c)}$	junction to case(AC)	TO-3P Ins	0.65	$^\circ\text{C/W}$
		TO-247S/ TO-247J	0.60	
		TG-C	0.63	

ORDERING INFORMATION

<p>JieJie Microelectronics Co.,Ltd</p>	<p>J</p> <p>SCRs</p> <p>6: $V_{DRM}/V_{RRM} \geq 600V$ 8: $V_{DRM}/V_{RRM} \geq 800V$</p>	<p>CT</p>	<p>6</p>	<p>55</p> <p>$I_{T(RMS)}: 55A$</p>	<p>Z</p> <p>T: TG-C Z: TO-3P Ins CS: TO-247S SJ: TO-247J</p>
--	--	------------------	-----------------	--	---

PACKAGE MECHANICAL DATA

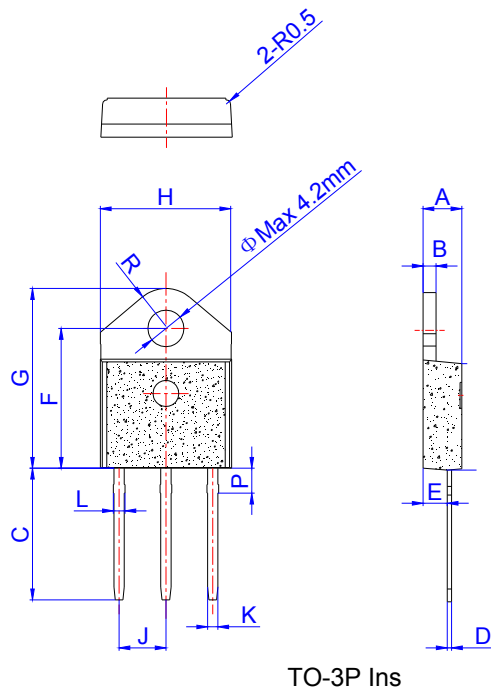

Ref.	Dimensions					
	Millimeters			Inches		
	Min.	Typ.	Max.	Min.	Typ.	Max.
A	4.40		4.60	0.173		0.181
B	1.45		1.55	0.057		0.061
C	14.35		15.60	0.565		0.614
D	0.50		0.70	0.020		0.028
E	2.70		2.90	0.106		0.114
F	15.80		16.50	0.622		0.650
G	20.40		21.10	0.803		0.831
H	15.10		15.50	0.594		0.610
J	5.40		5.65	0.213		0.222
K	1.10		1.40	0.043		0.055
L	1.35		1.50	0.053		0.059
P	2.80		3.00	0.110		0.118
R		4.35			0.171	

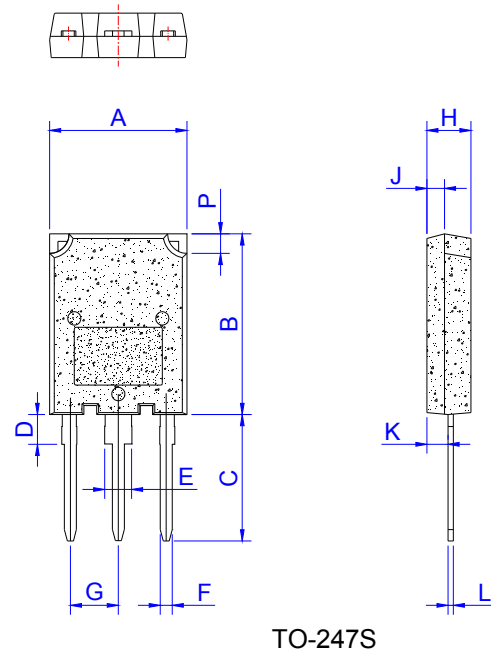

Ref.	Dimensions					
	Millimeters			Inches		
	Min.	Typ.	Max.	Min.	Typ.	Max.
A	15.1		16.1	0.594		0.634
B	19.8		20.8	0.78		0.819
C	13.8		14.8	0.543		0.583
D	3.00		4.00	0.118		0.157
E	2.75		3.35	0.108		0.132
F	1.30		1.50	0.051		0.059
G	5.10		5.80	0.201		0.228
H	4.50		5.50	0.177		0.217
J	1.45		2.15	0.057		0.085
K	1.90		2.80	0.075		0.110
L	0.55		0.80	0.022		0.031
P	2.00		2.40	0.079		0.094

PACKAGE MECHANICAL DATA

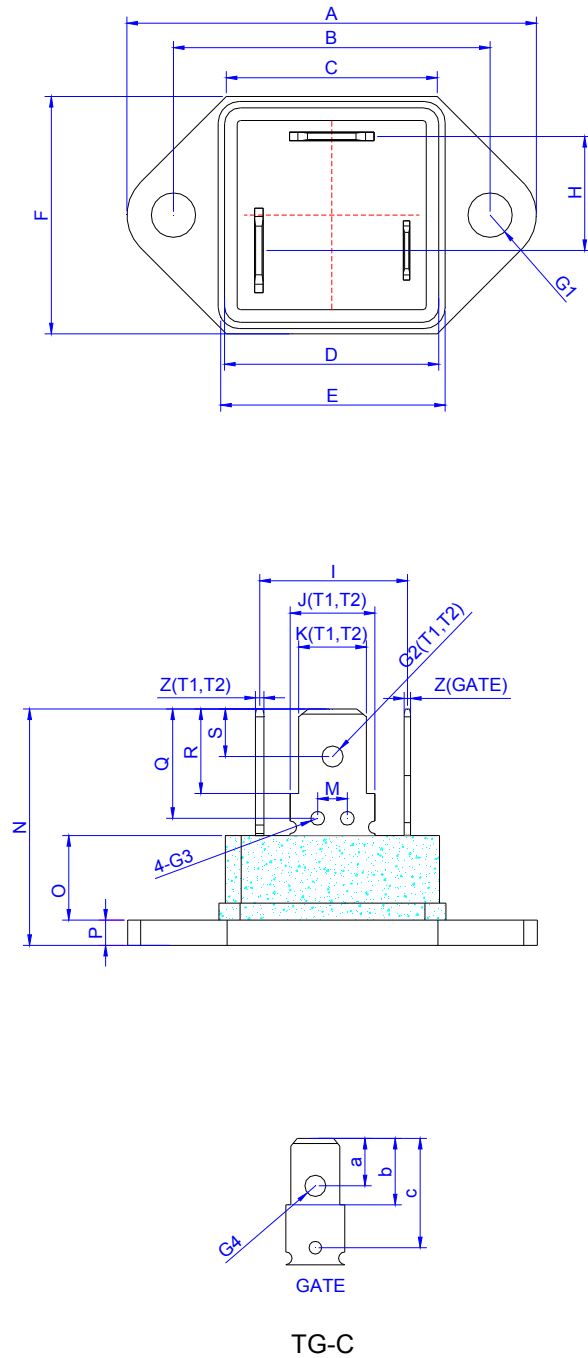

Ref.	Dimensions					
	Millimeters			Inches		
	Min.	Typ.	Max.	Min.	Typ.	Max.
A			39.2			1.543
B	29.8	30.0	30.2	1.173	1.181	1.189
C			20.2			0.795
D			20.5			0.807
E			21.6			0.85
F			23			0.905
G1	Φ4.1	Φ4.2	Φ4.3	Φ0.161	Φ0.165	Φ0.169
H		10.3			0.406	
I		13.9			0.547	
J(T1,T2)		8			0.315	
K(T1,T2)		6.4			0.252	
M	2.7	3.0	3.3	0.106	0.118	0.130
N			22.8			0.898
O		8.2			0.323	
P		2.5			0.098	
Q	9.45	9.75	10.1	0.374	0.383	0.398
R	7.8	7.95	8.1	0.307	0.313	0.319
S	4.3	4.5	4.7	0.169	0.177	0.185
Z(T1,T2)	0.78	0.8	0.85	0.0307	0.0315	0.0335
G2(T1,T2)		Φ2	Φ2.2		Φ0.079	Φ0.087
G3	Φ1.1	Φ1.3	Φ1.5	Φ0.043	Φ0.051	Φ0.059
G4		Φ1.55	Φ1.75		Φ0.061	Φ0.069
a	2.95	3.15	3.35	0.116	0.124	0.132
b	6.2	6.35	6.5	0.244	0.25	0.256
c	9.35	9.75	10	0.368	0.384	0.393
Z(GATE)	0.58	0.6	0.65	0.0228	0.0236	0.0256
J(GATE)		5.6			0.221	
K(GATE)		4.65			0.183	

PACKAGE MECHANICAL DATA

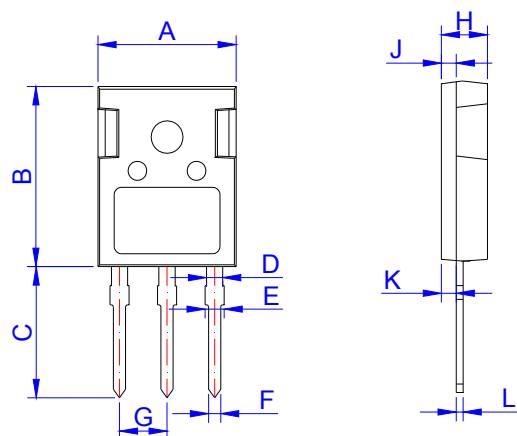

TO-247J

Ref.	Dimensions					
	Millimeters			Inches		
	Min.	Typ.	Max.	Min.	Typ.	Max.
A	15.50	15.80	16.10	0.610	0.622	0.634
B	20.80	21.00	22.20	0.819	0.828	0.874
C	19.70	20.00	20.30	0.776	0.787	0.799
D	1.80	2.00	2.20	0.071	0.079	0.087
E	1.90	2.10	2.30	0.075	0.083	0.091
F	1.00	1.20	1.40	0.039	0.047	0.055
G		5.44			0.214	
H	4.80	5.00	5.20	0.189	0.197	0.205
J	1.90	2.00	2.10	0.075	0.079	0.083
K	2.20	2.35	2.50	0.087	0.093	0.098
L	0.41	0.60	0.79	0.016	0.024	0.031

PACKAGE INFORMATION

PACKAGE	OUTLINE	TUBE (PCS)	INNER BOX (PCS)	PER CARTON
TO-3P	TUBE	30	450	3,600
TO-247S	TUBE	30	450	3,600
TO-247J	TUBE	30	450	3,600
PACKAGE	WEIGHT (PER PCS)	OUTLINE	INNER BOX (PCS)	PER CARTON (PCS)
TG-C	21.5g	BOX	80	720

FIG.1: Maximum power dissipation versus RMS on-state current

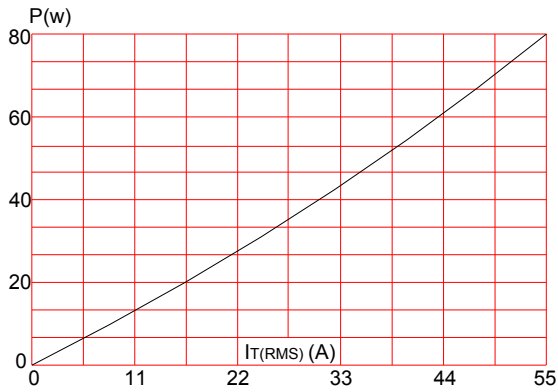

FIG.2: RMS on-state current versus case temperature

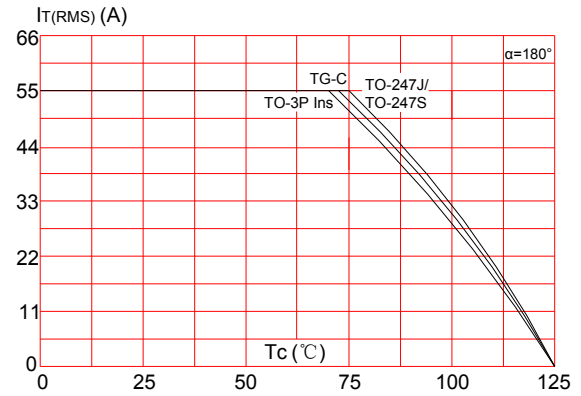

FIG.3: Surge peak on-state current versus number of cycles

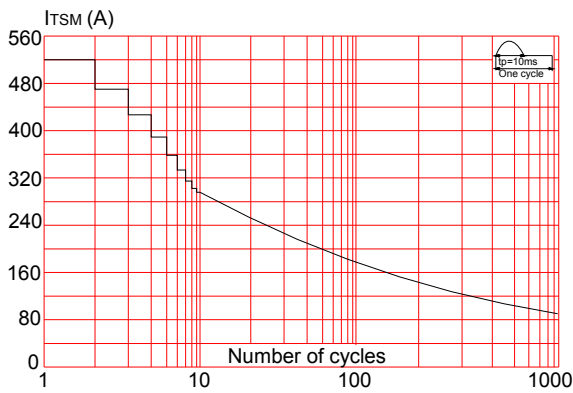

FIG.4: On-state characteristics (maximum values)

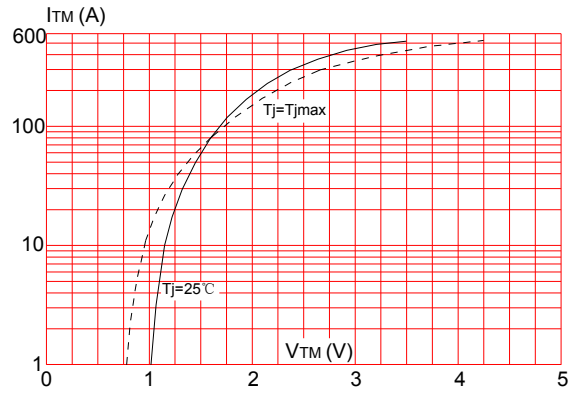

FIG.5: Non-repetitive surge peak on-state current for a sinusoidal pulse with width $t_p < 10\text{ms}$, and corresponding value of I^2t ($di/dt < 150\text{A}/\mu\text{s}$)

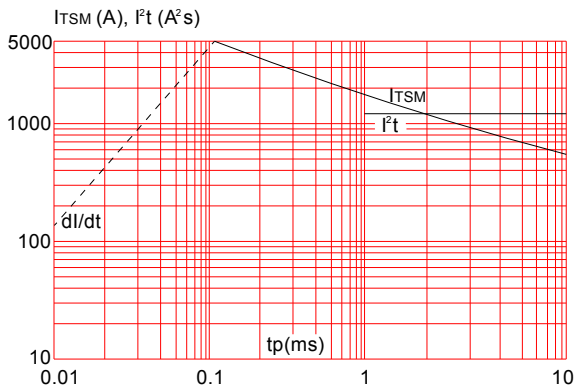
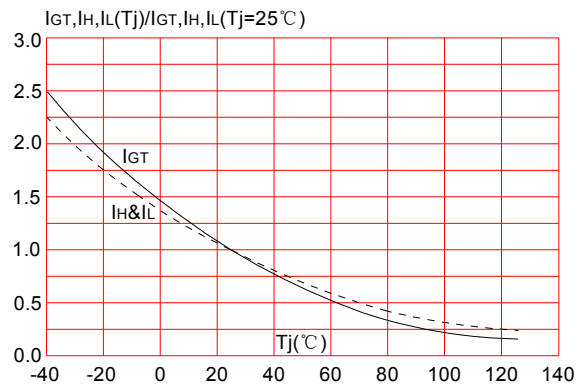



FIG.6: Relative variations of gate trigger current, holding current and latching current versus junction temperature



Information furnished in this document is believed to be accurate and reliable. However, Jiangsu JieJie Microelectronics Co.,Ltd assumes no responsibility for the consequences of use without consideration for such information nor use beyond it. Information mentioned in this document is subject to change without notice, apart from that when an agreement is signed, Jiangsu JieJie complies with the agreement. Products and information provided in this document have no infringement of patents. Jiangsu JieJie assumes no responsibility for any infringement of other rights of third parties which may result from the use of such products and information. This document is the sixth version which is made in 22-Dec.-2018. This document supersedes and replaces all information previously supplied.

 is a registered trademark of Jiangsu JieJie Microelectronics Co.,Ltd.
Copyright ©2018 Jiangsu JieJie Microelectronics Co.,Ltd. Printed All rights reserved.
