

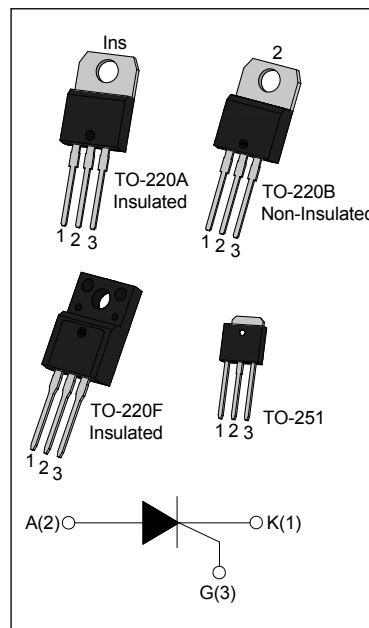

DESCRIPTION:

With high ability to withstand the shock loading of large current, JCTx12 series of silicon controlled rectifiers provide high dv/dt rate with strong resistance to electromagnetic interference. They are especially recommended for use on solid state relay, motorcycle, power charger, T-tools etc.

From all three terminals to external heatsink, JCTx12A provides a rated insulation voltage of 2500 V_{RMS}, and JCTx12F provides a rated insulation voltage of 2000 V_{RMS}, complying with UL standards (File ref: E252906).



MAIN FEATURES

Symbol	JCT612	JCT812
V _{DRM} / V _{RRM}	600V	800V
I _{T(RMS)}	12A	
I _{GT}	≤15mA	

ABSOLUTE MAXIMUM RATINGS

Parameter	Symbol	Value	Unit
Storage junction temperature range	T _{stg}	-40-150	°C
Operating junction temperature range	T _j	-40-150	°C
Repetitive peak off-state voltage(T _j =25°C)	V _{DRM}	600/800	V
Repetitive peak reverse voltage(T _j =25°C)	V _{RRM}	600/800	V
Non repetitive surge peak Off-state voltage	V _{DSM}	V _{DRM} +100	V
Non repetitive peak reverse voltage	V _{RSM}	V _{RRM} +100	V
RMS on-state current	TO-251 (T _c =120°C)	12	A
	TO-220A(Ins)/ TO-220F(Ins) (T _c =110°C)		

RMS on-state current	TO-220B(Non-Ins) ($T_C=125^\circ\text{C}$)	$I_{T(RMS)}$	12	A
Non repetitive surge peak on-state current ($t_p=10\text{ms}$)		I_{TSM}	140	A
I^2t value for fusing ($t_p=10\text{ms}$)		I^2t	98	A^2s
Critical rate of rise of on-state current ($I_G=2 \times I_{GT}$)		di/dt	50	$\text{A}/\mu\text{s}$
Peak gate current		I_{GM}	4	A
Average gate power dissipation		$P_{G(AV)}$	1	W
Peak gate power		P_{GM}	5	W

ELECTRICAL CHARACTERISTICS ($T_j=25^\circ\text{C}$ unless otherwise specified)

Symbol	Test Condition	Value			Unit
		MIN.	TYP.	MAX.	
I_{GT}	$V_D=12\text{V } R_L=33\Omega$	-	-	15	mA
V_{GT}		-	-	1.5	V
V_{GD}	$V_D=V_{DRM} T_j=150^\circ\text{C} R_L=3.3\text{K}\Omega$	0.2	-	-	V
I_L	$I_G=1.2I_{GT}$	-	-	60	mA
I_H	$I_T=500\text{mA}$	-	-	50	mA
dV/dt	$V_D=2/3V_{DRM}$ Gate Open $T_j=150^\circ\text{C}$	200	-	-	$\text{V}/\mu\text{s}$

STATIC CHARACTERISTICS

Symbol	Parameter		Value(MAX)	Unit
V_{TM}	$I_{TM}=24\text{A } t_p=380\mu\text{s}$	$T_j=25^\circ\text{C}$	1.55	V
I_{DRM}	$V_D=V_{DRM} V_R=V_{RRM}$	$T_j=25^\circ\text{C}$	5	μA
I_{RRM}		$T_j=150^\circ\text{C}$	2	mA

THERMAL RESISTANCES

Symbol	Parameter	Value	Unit
R _{th(j-c)}	junction to case(AC)	TO-220A(Ins)	2.3
		TO-220B(Non-Ins)	1.3
		TO-220F(Ins)	2.5
		TO-251	1.8

ORDERING INFORMATION

<p>J</p> <p>JieJie Microelectronics Co.,Ltd</p>	<p>CT</p> <p>SCRs</p>	<p>6</p> <p>6:V_{DRM} /V_{RRM} ≥600V 8:V_{DRM} /V_{RRM} ≥800V</p>	<p>12</p> <p>I_{T(RMS)}:12A</p>	<p>B</p> <p>H:TO-251 A:TO-220A(Ins) F:TO-220F(Ins) B:TO-220B(Non-Ins)</p>
---	-----------------------	---	---	---

PACKAGE MECHANICAL DATA

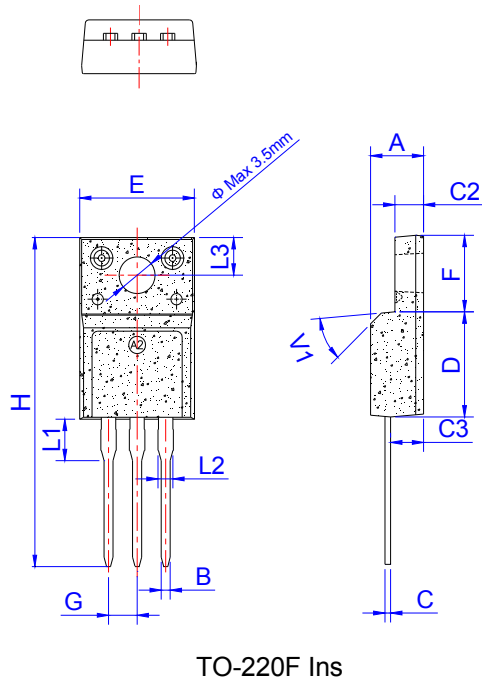

Ref.	Dimensions					
	Millimeters			Inches		
	Min.	Typ.	Max.	Min.	Typ.	Max.
A	4.50		4.90	0.177		0.193
B	0.74	0.80	0.83	0.029	0.031	0.033
C	0.47		0.65	0.019		0.026
C2	2.45		2.75	0.096		0.108
C3	2.60		3.00	0.102		0.118
D	8.80		9.30	0.346		0.366
E	9.80		10.4	0.386		0.410
F	6.40		6.80	0.252		0.268
G		2.54			0.1	
H	28.0		29.8	1.102		1.173
L1		3.63			0.143	
L2	1.14		1.70	0.045		0.067
L3		3.30			0.130	
V1		45°			45°	

PACKAGE MECHANICAL DATA

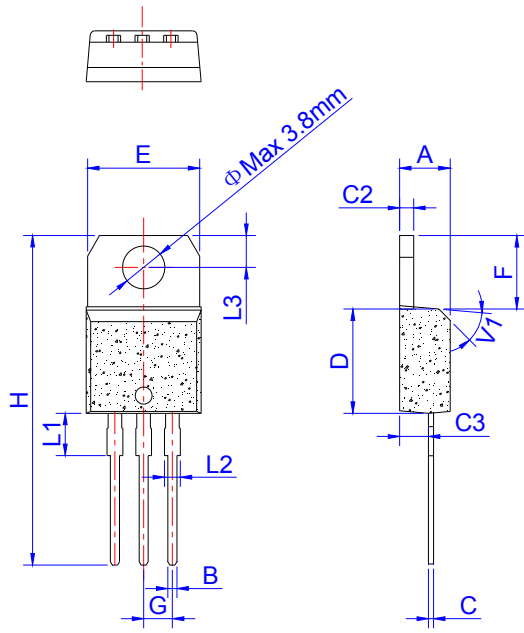

TO-220A Ins

Ref.	Dimensions					
	Millimeters			Inches		
	Min.	Typ.	Max.	Min.	Typ.	Max.
A	4.40		4.60	0.173		0.181
B	0.61		0.88	0.024		0.035
C	0.46		0.70	0.018		0.028
C2	1.21		1.32	0.048		0.052
C3	2.40		2.72	0.094		0.107
D	8.60		9.70	0.339		0.382
E	9.80		10.4	0.386		0.409
F	6.55		6.95	0.258		0.274
G		2.54			0.1	
H	28.0		29.8	1.102		1.173
L1		3.75			0.148	
L2	1.14		1.70	0.045		0.067
L3	2.65		2.95	0.104		0.116
V1		45°			45°	

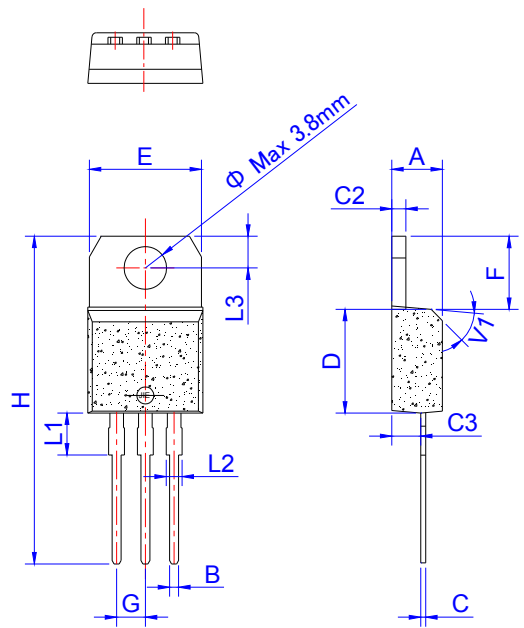

TO-220B Non-Ins

Ref.	Dimensions					
	Millimeters			Inches		
	Min.	Typ.	Max.	Min.	Typ.	Max.
A	4.40		4.60	0.173		0.181
B	0.61		0.88	0.024		0.035
C	0.46		0.70	0.018		0.028
C2	1.21		1.32	0.048		0.052
C3	2.40		2.72	0.094		0.107
D	8.60		9.70	0.339		0.382
E	9.60		10.4	0.378		0.409
F	6.20		6.60	0.244		0.260
G		2.54			0.1	
H	28.0		29.8	1.102		1.173
L1		3.75			0.148	
L2	1.14		1.70	0.045		0.067
L3	2.65		2.95	0.104		0.116
V1		45°			45°	

PACKAGE MECHANICAL DATA

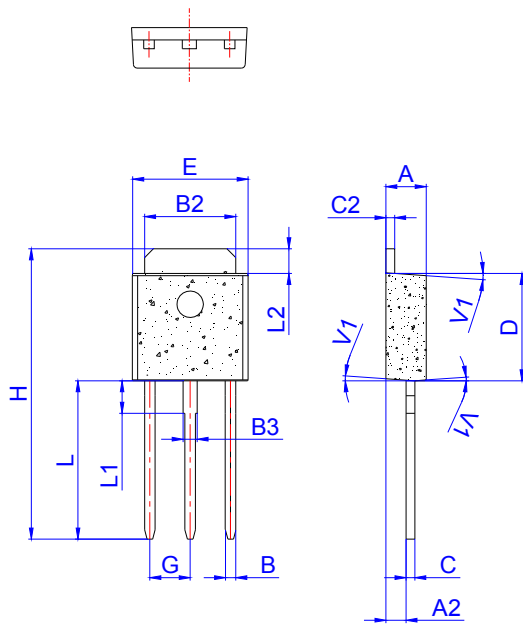

TO-251

Ref.	Dimensions					
	Millimeters			Inches		
	Min.	Typ.	Max.	Min.	Typ.	Max.
A	2.20		2.40	0.086		0.095
A2	0.90		1.20	0.035		0.047
B	0.55		0.65	0.022		0.026
B2	5.10		5.40	0.200		0.213
B3	0.76		0.85	0.030		0.033
C	0.45		0.62	0.018		0.024
C2	0.48		0.62	0.019		0.024
D	6.00		6.20	0.236		0.244
E	6.40		6.70	0.252		0.264
G		2.30			0.091	
H	16.0		17.0	0.630		0.669
L	8.90		9.40	0.350		0.370
L1	1.80		1.90	0.071		0.075
L2	1.37		1.50	0.054		0.059
V1		4°			4°	

MARKING

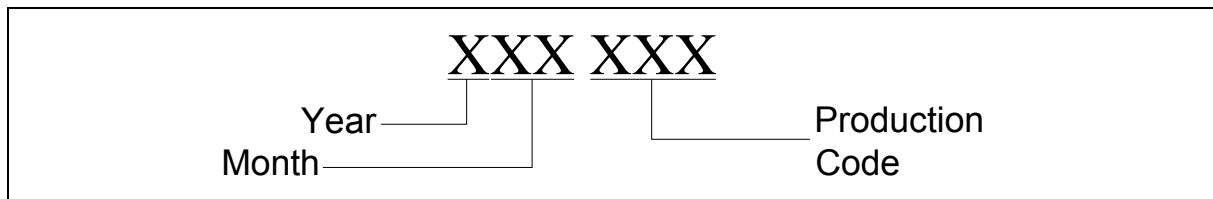
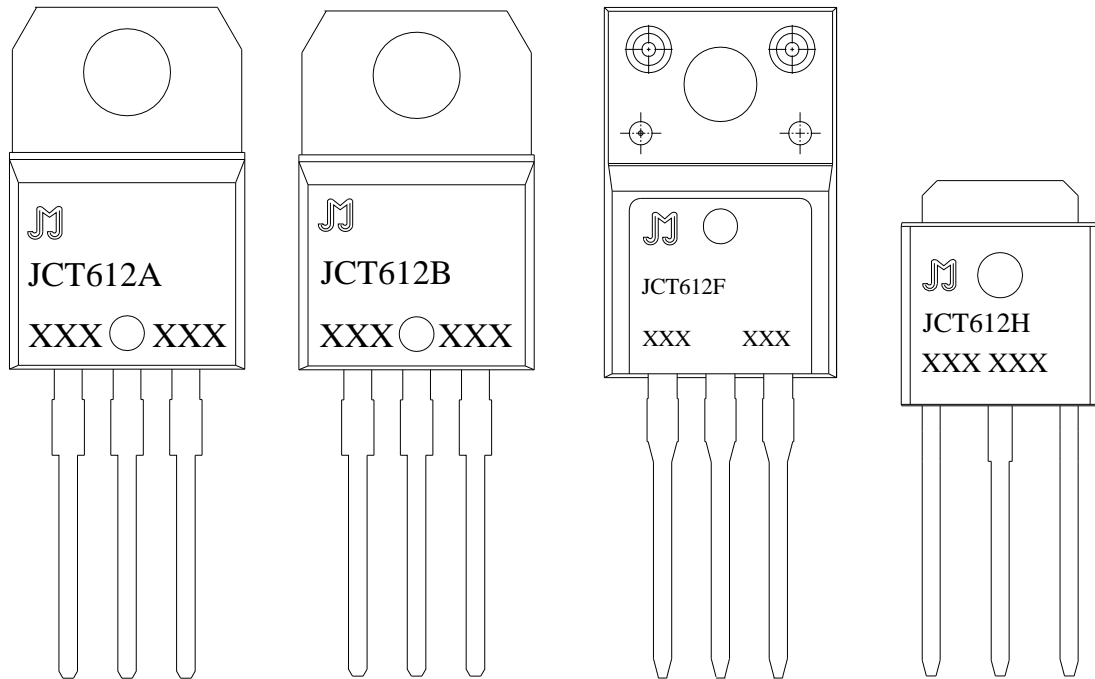

PACKAGE INFORMATION

PACKAGE	OUTLINE	TUBE (PCS)	INNER BOX (PCS)	PER CARTON
TO-251	TUBE	80	4,000	32,000
PACKAGE	OUTLINE	TUBE (PCS)	INNER BOX (PCS)	PER CARTON
TO-220A	TUBE	50	1,000	8,000
TO-220B	TUBE	50	1,000	8,000
TO-220F	TUBE	50	1,000	8,000

FIG.1: Maximum power dissipation versus RMS on-state current

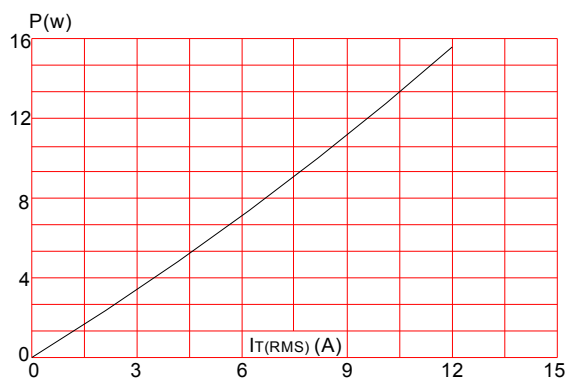

FIG.3: Surge peak on-state current versus number of cycles

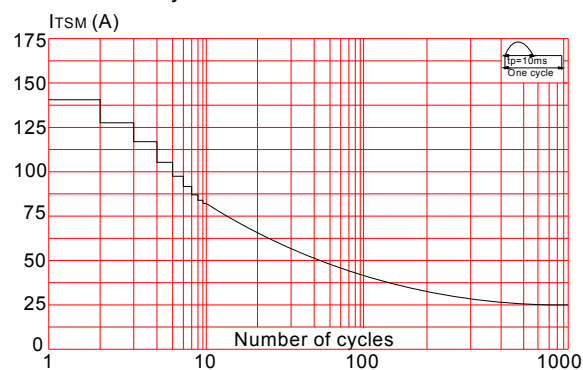

FIG.5: Non-repetitive surge peak on-state current for a sinusoidal pulse with width $t_p < 10\text{ms}$, and corresponding value of I^2t ($di/dt < 50\text{A}/\mu\text{s}$)

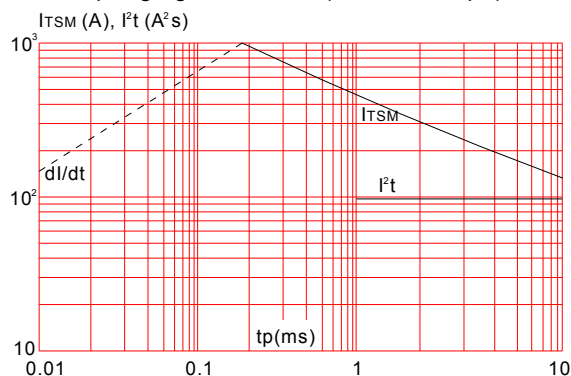

FIG.2: RMS on-state current versus case temperature

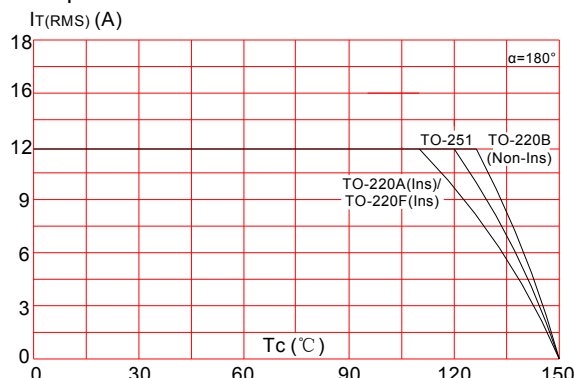

FIG.4: On-state characteristics (maximum values)

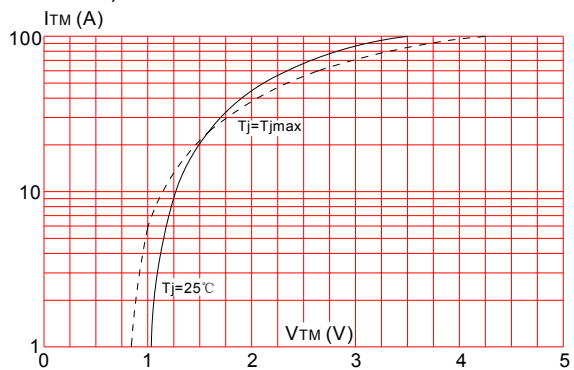
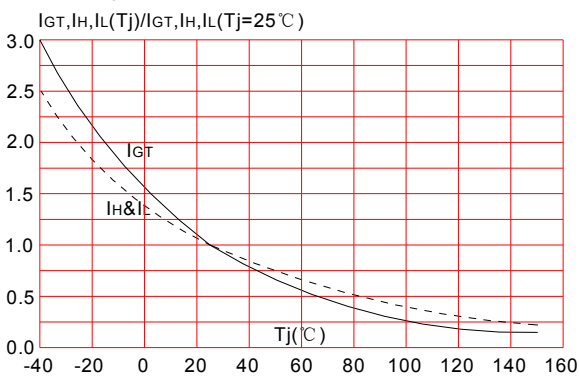



FIG.6: Relative variations of gate trigger current, holding current and latching current versus junction temperature



Information furnished in this document is believed to be accurate and reliable. However, Jiangsu JieJie Microelectronics Co.,Ltd assumes no responsibility for the consequences of use without consideration for such information nor use beyond it. Information mentioned in this document is subject to change without notice, apart from that when an agreement is signed, Jiangsu JieJie complies with the agreement. Products and information provided in this document have no infringement of patents. Jiangsu JieJie assumes no responsibility for any infringement of other rights of third parties which may result from the use of such products and information. This document is the tenth version which is made in 26-Jan.-2019. This document supersedes and replaces all information previously supplied.

 is a registered trademark of Jiangsu JieJie Microelectronics Co.,Ltd.

Copyright ©2019 Jiangsu JieJie Microelectronics Co.,Ltd. Printed All rights reserved.