

T16xxH Series 16A TRIACs

Rev.5.0

DESCRIPTION:

T16xxH series triacs of high junction temperature with high dv/dt rate with strong resistance to electromagnetic interference provide high ability to withstand the shock loading of large current. They are especially recommended for use on inductive load and high environment temperature condition.

T16xxH-xxA provides insulation voltage rated at 2500V RMS and T16xxH-xxF provides insulation voltage rated at 2000V_{RMS} from all three terminals to external heatsink complying with UL standards (File ref: E252906).

MAIN FEATURES

Symbol	Value	Unit
$I_{T(RMS)}$	16	A
V_{DRM}/V_{RRM}	600/800	V
T_{jmax}	150	°C

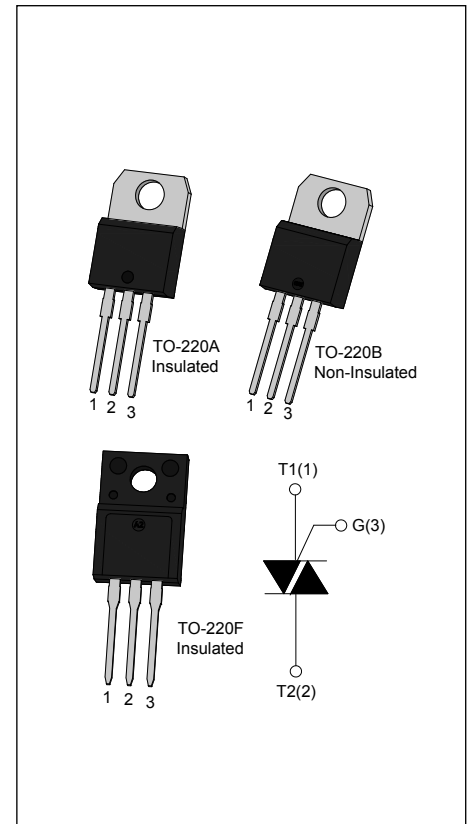

ABSOLUTE MAXIMUM RATINGS

Parameter		Symbol	Value	Unit
Storage junction temperature range		T_{stg}	-40-150	°C
Operating junction temperature range		T_j	-40-150	°C
Repetitive peak off-state voltage($T_j=25^\circ\text{C}$)		V_{DRM}	600/800	V
Repetitive peak reverse voltage($T_j=25^\circ\text{C}$)		V_{RRM}	600/800	V
RMS on-state current	TO-220A(Ins)/ TO-220F(Ins) ($T_c=100^\circ\text{C}$)	$I_{T(RMS)}$	16	A
	TO-220B(Non-Ins) ($T_c=125^\circ\text{C}$)			
Non repetitive surge peak on-state current (full cycle, $F=50\text{Hz}$)		I_{TSM}	160	A
I^2t value for fusing ($t_p=10\text{ms}$)		I^2t	144	A ² s
Critical rate of rise of on-state current ($I_G=2 \times I_{GT}$)		di/dt	50	A/ μs

Peak gate current	I_{GM}	4	A
Average gate power dissipation	$P_{G(AV)}$	1	W
Peak gate power	P_{GM}	5	W

ELECTRICAL CHARACTERISTICS ($T_j=25^{\circ}\text{C}$ unless otherwise specified)

Symbol	Test Condition	Quadrant		Value				Unit
				T1610H	T1620H	T1635H	T1650H	
I_{GT}	$V_D=12\text{V } R_L=33\Omega$	I - II - III	MAX	10	20	35	50	mA
V_{GT}		I - II - III	MAX	1.5				V
V_{GD}	$V_D=V_{DRM} T_j=150^{\circ}\text{C}$ $R_L=3.3\text{K}\Omega$	I - II - III	MIN	0.2				V
I_L	$I_G=1.2I_{GT}$	I - III	MAX	20	40	50	80	mA
		II		35	55	70	100	
I_H	$I_T=100\text{mA}$		MAX	20	30	45	70	mA
dV/dt	$V_D=2/3V_{DRM} R_{GK}=1\text{K}\Omega T_j=150^{\circ}\text{C}$		MIN	200	500	1000	1500	V/ μs

STATIC CHARACTERISTICS

Symbol	Parameter		Value(MAX)	Unit
V_{TM}	$I_{TM}=22.5\text{A } t_p=380\mu\text{s}$	$T_j=25^{\circ}\text{C}$	1.4	V
I_{DRM}	$V_D=V_{DRM} V_R=V_{RRM}$	$T_j=25^{\circ}\text{C}$	5	μA
I_{RRM}		$T_j=150^{\circ}\text{C}$	2	mA

THERMAL RESISTANCES

Symbol	Parameter		Value	Unit
$R_{th(j-c)}$	junction to case(AC)	TO-220A(Ins)	2.1	$^{\circ}\text{C/W}$
		TO-220B(Non-Ins)	1.2	
		TO-220F(Ins)	2.3	

ORDERING INFORMATION

<p>T</p> <p>Triacs</p> <p>$I_T(RMS):16A$</p> <p>10: $I_{GT1-3} \leq 10mA$</p> <p>20: $I_{GT1-3} \leq 20mA$</p> <p>35: $I_{GT1-3} \leq 35mA$</p> <p>50: $I_{GT1-3} \leq 50mA$</p>	<p>16</p>	<p>20</p>	<p>H</p>	<p>-6</p>	<p>B</p> <p>A: TO-220A(Ins)</p> <p>F: TO-220F(Ins)</p> <p>B: TO-220B(Non-Ins)</p> <p>6: $V_{DRM} / V_{RRM} \geq 600V$</p> <p>8: $V_{DRM} / V_{RRM} \geq 800V$</p> <p>High junction temperature</p>
--	------------------	------------------	-----------------	------------------	---

PACKAGE MECHANICAL DATA

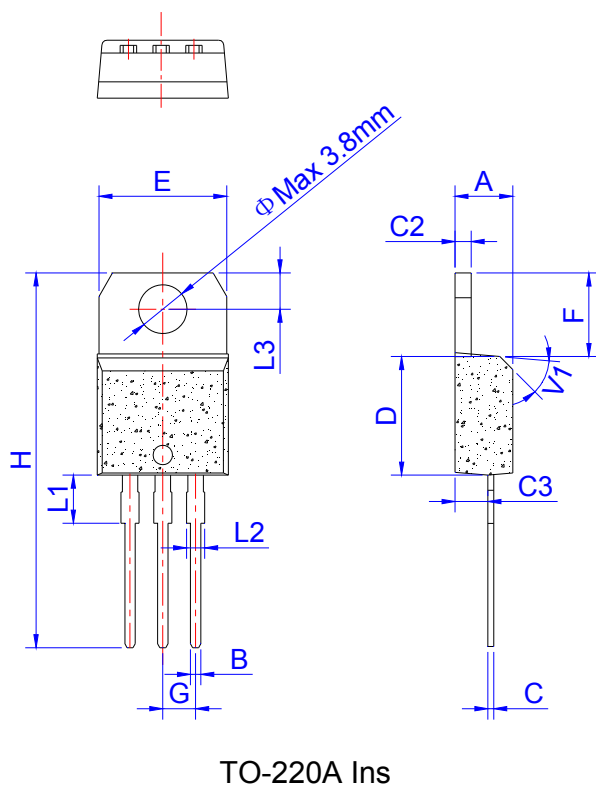

Ref.	Dimensions					
	Millimeters			Inches		
	Min.	Typ.	Max.	Min.	Typ.	Max.
A	4.40		4.60	0.173		0.181
B	0.61		0.88	0.024		0.035
C	0.46		0.70	0.018		0.028
C2	1.21		1.32	0.048		0.052
C3	2.40		2.72	0.094		0.107
D	8.60		9.70	0.339		0.382
E	9.80		10.4	0.386		0.409
F	6.55		6.95	0.258		0.274
G		2.54			0.1	
H	28.0		29.8	1.102		1.173
L1		3.75			0.148	
L2	1.14		1.70	0.045		0.067
L3	2.65		2.95	0.104		0.116
V1		45°			45°	

PACKAGE MECHANICAL DATA

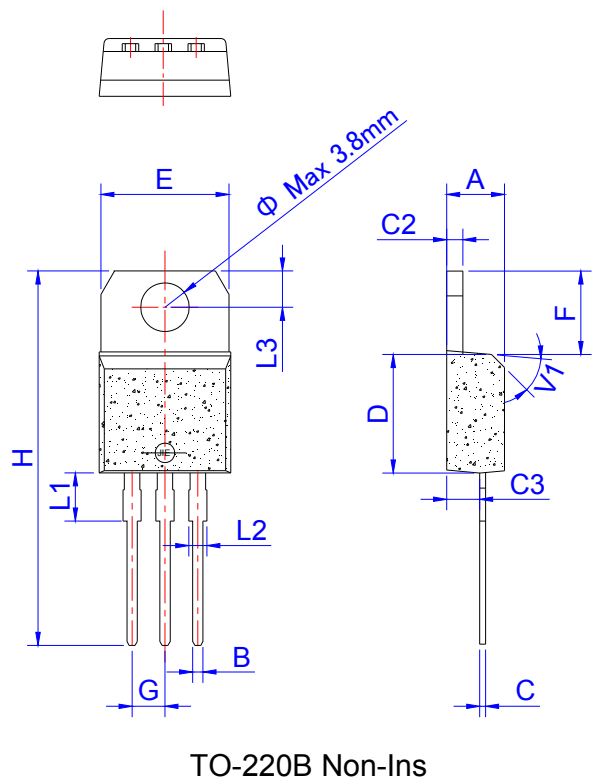

Ref.	Dimensions					
	Millimeters			Inches		
	Min.	Typ.	Max.	Min.	Typ.	Max.
A	4.40		4.60	0.173		0.181
B	0.61		0.88	0.024		0.035
C	0.46		0.70	0.018		0.028
C2	1.21		1.32	0.048		0.052
C3	2.40		2.72	0.094		0.107
D	8.60		9.70	0.339		0.382
E	9.60		10.4	0.378		0.409
F	6.20		6.60	0.244		0.260
G		2.54			0.1	
H	28.0		29.8	1.102		1.173
L1		3.75			0.148	
L2	1.14		1.70	0.045		0.067
L3	2.65		2.95	0.104		0.116
V1		45°			45°	

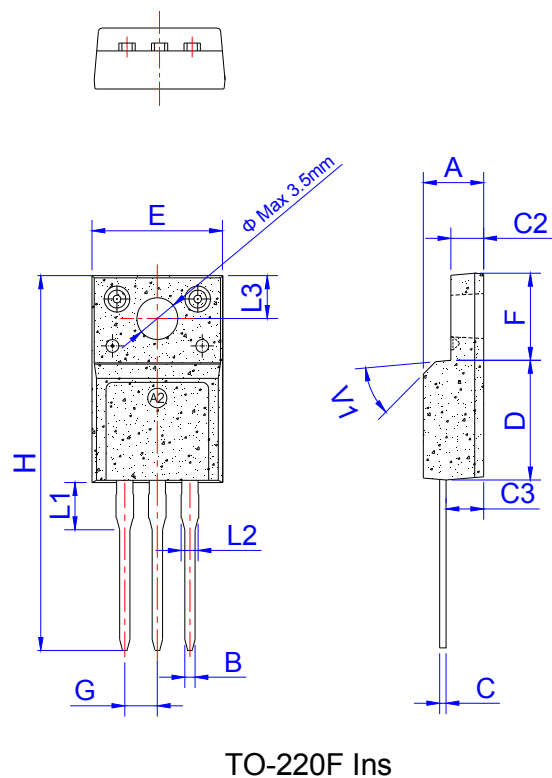

Ref.	Dimensions					
	Millimeters			Inches		
	Min.	Typ.	Max.	Min.	Typ.	Max.
A	4.50		4.90	0.177		0.193
B	0.74	0.80	0.83	0.029	0.031	0.033
C	0.47		0.65	0.019		0.026
C2	2.45		2.75	0.096		0.108
C3	2.60		3.00	0.102		0.118
D	8.80		9.30	0.346		0.366
E	9.80		10.4	0.386		0.410
F	6.40		6.80	0.252		0.268
G		2.54			0.1	
H	28.0		29.8	1.102		1.173
L1		3.63			0.143	
L2	1.14		1.70	0.045		0.067
L3		3.30			0.130	
V1		45°			45°	

MARKING

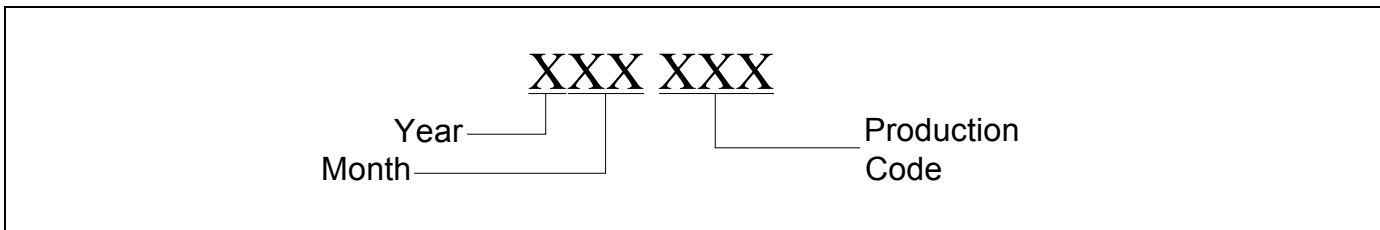
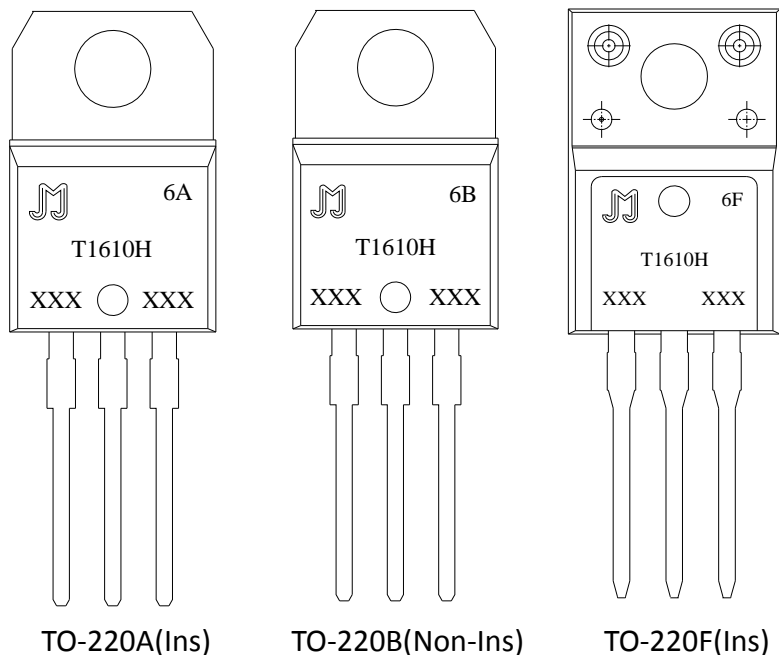

FIG.1 Maximum power dissipation versus RMS on-state current

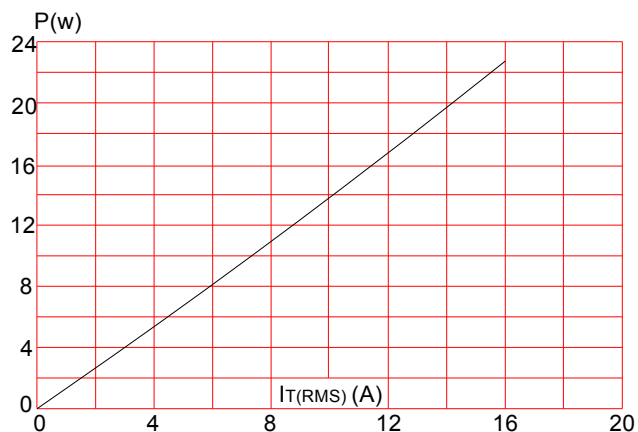

FIG.2: RMS on-state current versus case temperature

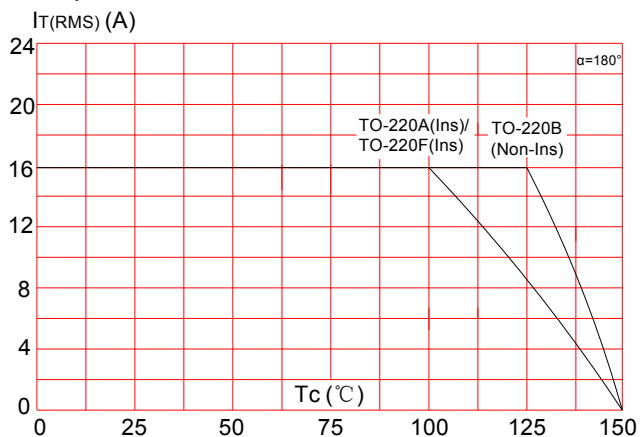

FIG.3: Surge peak on-state current versus number of cycles

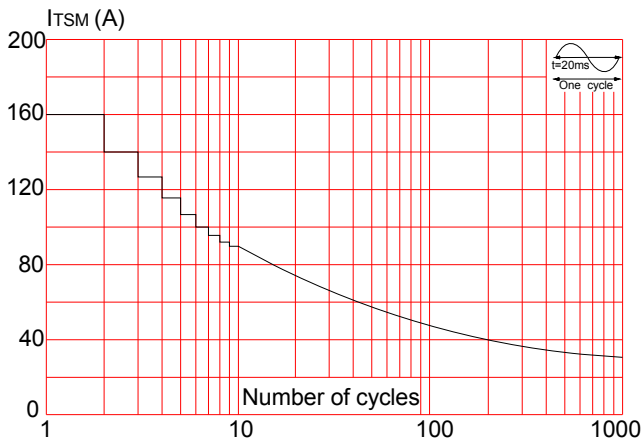

FIG.5: Non-repetitive surge peak on-state current for a sinusoidal pulse with width $t_p < 20\text{ms}$, and corresponding value of I^2t ($di/dt < 50\text{A}/\mu\text{s}$)

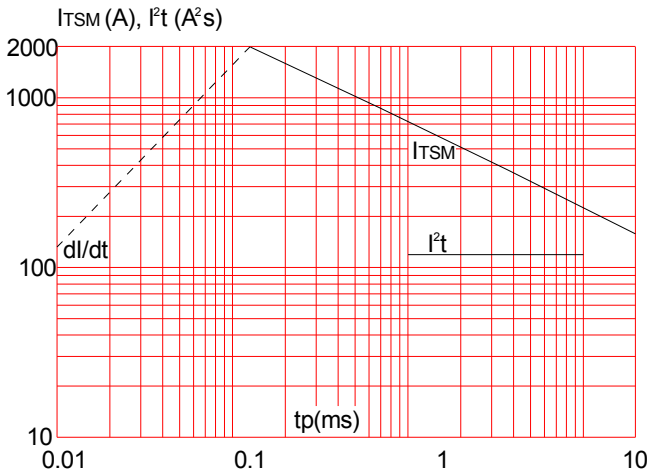

FIG.4: On-state characteristics (maximum values)

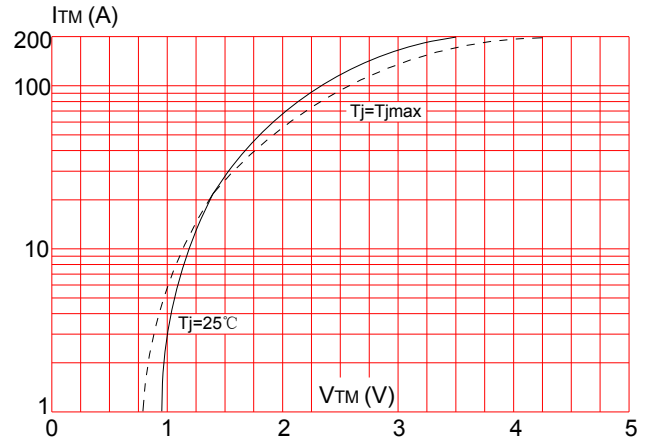
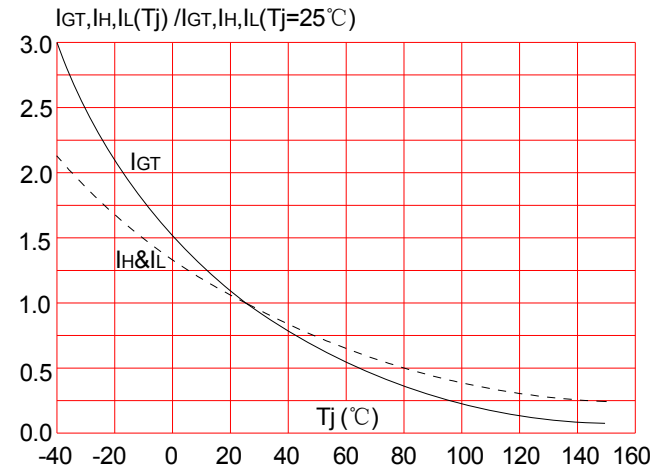

FIG.6: Relative variations of gate trigger current, holding current and latching current versus junction temperature



Information furnished in this document is believed to be accurate and reliable. However, Jiangsu JieJie Microelectronics Co.,Ltd assumes no responsibility for the consequences of use without consideration for such information nor use beyond it.

Information mentioned in this document is subject to change without notice, apart from that when an agreement is signed, Jiangsu JieJie complies with the agreement.

Products and information provided in this document have no infringement of patents. Jiangsu JieJie assumes no responsibility for any infringement of other rights of third parties which may result from the use of such products and information.

This document is the fifth version which is made in 24-May-2019. This document supersedes and replaces all information previously supplied.

 is a registered trademark of Jiangsu JieJie Microelectronics Co.,Ltd.

Copyright ©2019 Jiangsu JieJie Microelectronics Co.,Ltd. Printed All rights reserved.