

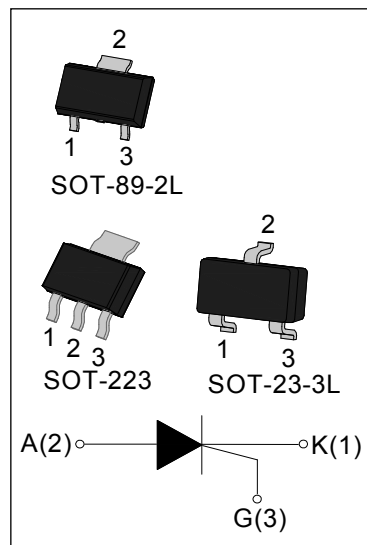


### DESCRIPTION:

The JX008 SCR series provide high dv/dt rate with strong resistance to electromagnetic interface. They are especially recommended for use on residual current circuit breaker, straight hair, igniter etc. All the packages mentioned are RoHS compliant. (2011/65/EU)

### MAIN FEATURES

Symbol	Value	Unit
$I_{T(RMS)}$	0.8	A
$I_{GT}$	$\leq 200$	$\mu A$



### ABSOLUTE MAXIMUM RATINGS

Parameter	Symbol	Value	Unit	
Storage junction temperature range	$T_{stg}$	-40-150	$^{\circ}C$	
Operating junction temperature range	$T_j$	-40-125 <sup>①</sup>	$^{\circ}C$	
Repetitive peak off-state voltage	$V_{DRM}$	600	V	
Repetitive peak reverse voltage	$V_{RRM}$	600	V	
RMS on-state current	SOT-23-3L ( $T_c=40^{\circ}C$ )	$I_{T(RMS)}$	0.8	A
	SOT-89-2L ( $T_c=70^{\circ}C$ )			
	SOT-223 ( $T_c=90^{\circ}C$ )			
Non repetitive surge peak on-state current (F=50Hz $t_p=10ms$ )	$I_{TSM}$	8	A	
Non repetitive surge peak on-state current (F=60Hz $t_p=8.3ms$ )	$I_{TSM}$	9	A	
$I^2t$ value for fusing ( $t_p=10ms$ )	$I^2t$	0.32	$A^2s$	
Critical rate of rise of on-state current	$di/dt$	50	$A/\mu s$	
Peak gate current ( $t_p=20\mu s$ , $T_j=125^{\circ}C$ )	$I_{GM}$	0.2	A	
Peak gate power ( $t_p=20\mu s$ , $T_j=125^{\circ}C$ )	$P_{GM}$	0.5	W	
Average gate power dissipation ( $T_j=125^{\circ}C$ )	$P_{G(AV)}$	0.1	W	

**NOTE 1:** When we parallel connect a  $\leq 1K\Omega$  resistor between Gate and Cathode, the  $T_j$  can reach  $125^{\circ}C$ ; if without this resistor, the  $T_j$  only can reach  $110^{\circ}C$ .

**ELECTRICAL CHARACTERISTICS** ( $T_j=25^{\circ}\text{C}$  unless otherwise specified)

Symbol	Test Condition	Value			Unit
		MIN.	TYP.	MAX.	
$I_{GT}$	$V_D=12\text{V } R_L=33\Omega$	20	50	200	$\mu\text{A}$
$V_{GT}$		-	0.6	0.8	V
$V_{GD}$	$V_D=V_{DRM} T_j=125^{\circ}\text{C}$	0.2	-	-	V
$I_L$	$I_G=1.2 I_{GT}$	-	-	4	mA
$I_H$	$I_T=0.05\text{A}$	-	-	3	mA
dV/dt	$V_D=400\text{V } T_j=125^{\circ}\text{C } R_{GK}=1\text{K}\Omega$	600	-	-	V/ $\mu\text{s}$
dV/dt	$V_D=400\text{V } T_j=125^{\circ}\text{C } R_{GK}=220\Omega$	1000	-	-	V/ $\mu\text{s}$
$t_{on}$	$I_G=10\text{mA } I_A=4\text{mA } I_R=0.4\text{mA}$ $T_j=25^{\circ}\text{C}$	-	2	-	$\mu\text{s}$
$t_{off}$		-	50	-	$\mu\text{s}$
$R_d$	Dynamic Resistance $T_j=125^{\circ}\text{C}$	-	-	35	$\text{m}\Omega$

**STATIC CHARACTERISTICS**

Symbol	Parameter		Value(MAX)	Unit
$V_{TM}$	$I_T=1.1\text{A } t_p=380\mu\text{s}$	$T_j=25^{\circ}\text{C}$	1.5	V
$I_{DRM}$	$V_D=V_{DRM} V_R=V_{RRM}$	$T_j=25^{\circ}\text{C}$	5	$\mu\text{A}$
$I_{RRM}$		$T_j=125^{\circ}\text{C}$	100	$\mu\text{A}$

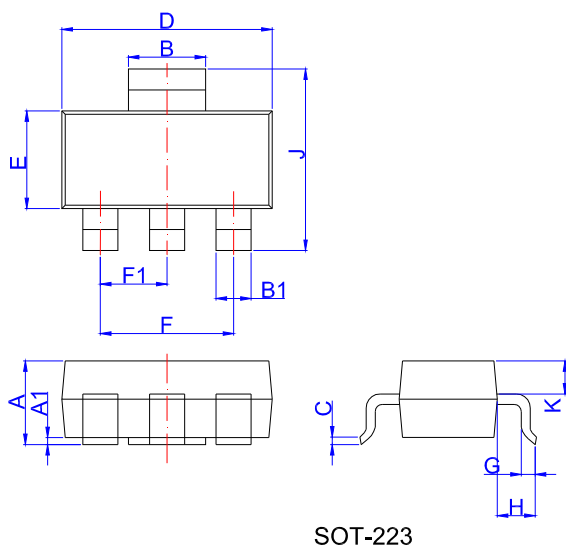
**THERMAL RESISTANCES**

Symbol	Parameter		Value	Unit
$R_{th(j-c)}$	junction to case	SOT-23-3L	75	$^{\circ}\text{C/W}$
		SOT-89-2L	45	
		SOT-223	31	
$R_{th(j-a)}$	junction to ambient	SOT-23-3L	125	$^{\circ}\text{C/W}$
		SOT-89-2L	90	
		SOT-223	60	

**ORDERING INFORMATION**

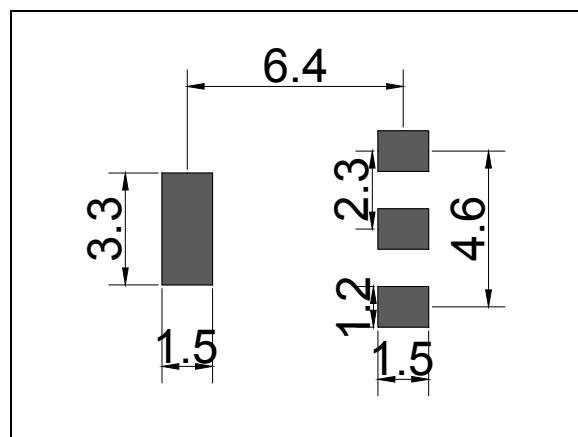
<p style="font-size: 2em; margin: 0;">J X 008 U</p> <p style="margin: 0;">JieJie Microelectronics Co.,Ltd</p> <p style="margin: 0;">Sensitive gate SCRs</p>	<p style="font-size: 2em; margin: 0;">U</p> <p style="margin: 0;">V:SOT-223 L:SOT-23-3L N2:SOT-89-2L</p> <p style="margin: 0;">IT(RMS):0.8A</p>
---	---

**PACKAGE MECHANICAL DATA**

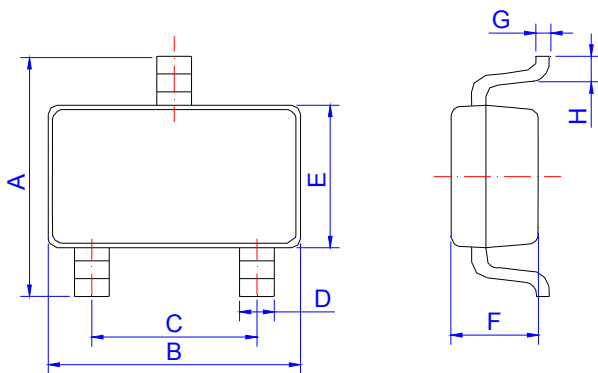


Ref.	Dimensions					
	Millimeters			Inches		
	Min.	Typ.	Max.	Min.	Typ.	Max.
A	1.5	1.6	1.8	0.059	0.063	0.071
A1	0.01	0.06	0.10	0.001	0.002	0.004
B	2.9	3.0	3.1	0.114	0.118	0.122
B1	0.6	0.7	0.8	0.024	0.028	0.031
C	0.22	0.26	0.32	0.009	0.010	0.013
D	6.3	6.5	6.7	0.248	0.256	0.264
E	3.3	3.5	3.7	0.130	0.138	0.146
F		4.6			0.181	
F1		2.3			0.091	
G	0.7	0.9	1.1	0.028	0.035	0.043
H	1.5	1.75	2.0	0.059	0.069	0.079
J	6.7	7.0	7.3	0.264	0.276	0.287
K	0.8	0.9	1.0	0.031	0.035	0.039

**FOOTPRINT-SOT-223 (dimensions in mm)**



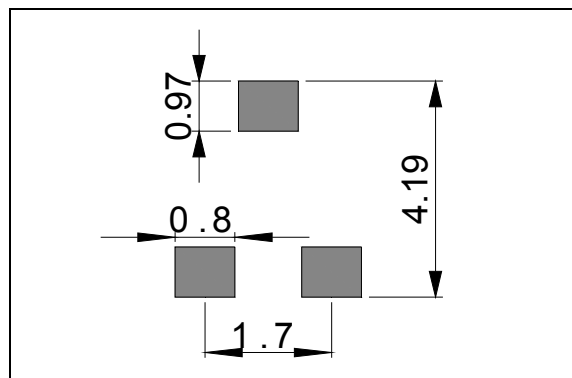
**PACKAGE MECHANICAL DATA**



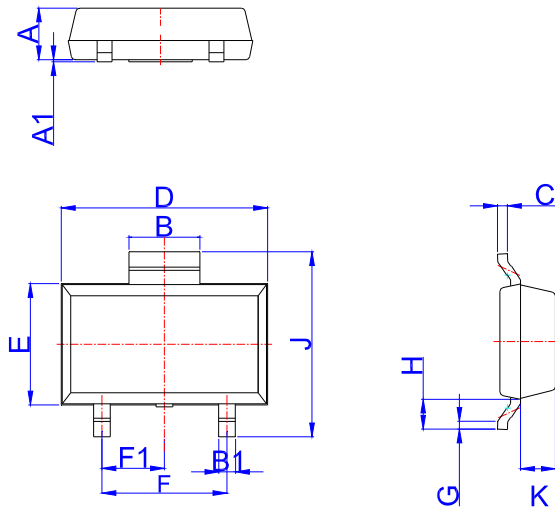
SOT-23-3L

Ref.	Dimensions					
	Millimeters			Inches		
	Min.	Typ.	Max.	Min.	Typ.	Max.
A	2.65	2.80	2.95	0.104	0.110	0.116
B	2.82	2.92	3.02	0.111	0.115	0.119
C	1.80	1.90	2.00	0.071	0.075	0.079
D	0.30	0.35	0.50	0.012	0.014	0.020
E	1.50	1.60	1.70	0.059	0.063	0.067
F	1.07	1.17	1.27	0.042	0.046	0.050
G	0.05	0.15	0.25	0.002	0.006	0.010
H	0.25	0.40	0.55	0.010	0.016	0.022

**FOOTPRINT-SOT-23-3L (dimensions in mm)**



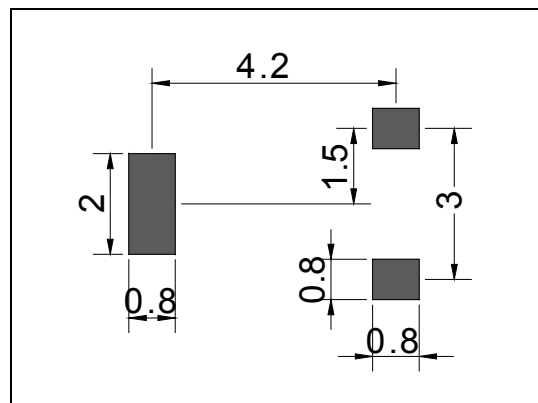
**PACKAGE MECHANICAL DATA**



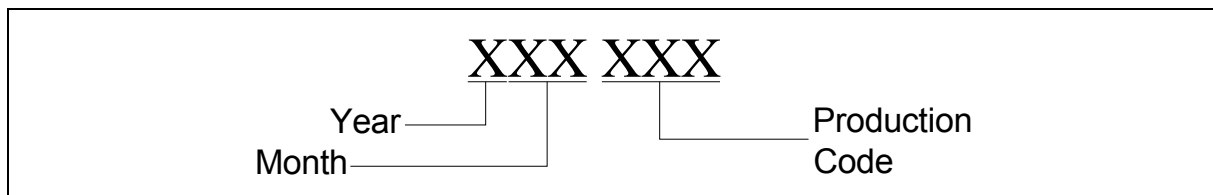
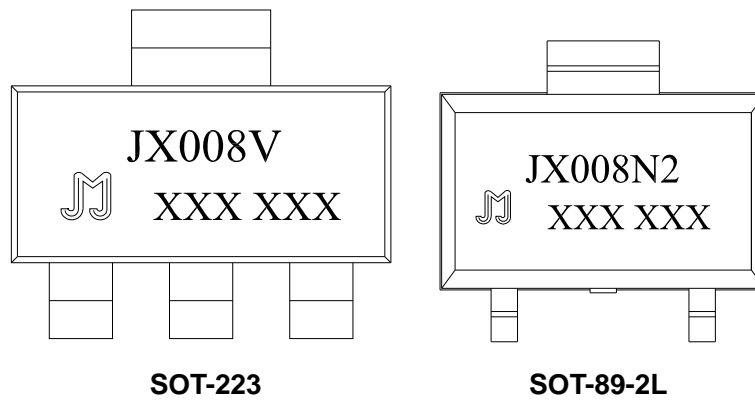
SOT-89-2L

Ref.	Dimensions					
	Millimeters			Inches		
	Min.	Typ.	Max.	Min.	Typ.	Max.
A	1.3	1.4	1.5	0.051	0.055	0.059
A1	0.01	0.06	0.10	0.001	0.002	0.004
B	1.6	1.7	1.8	0.063	0.067	0.071
B1	0.3	0.4	0.5	0.012	0.016	0.020
C	0.22	0.254	0.32	0.009	0.010	0.013
D	4.75	4.95	5.15	0.187	0.195	0.203
E	2.75	2.95	3.15	0.108	0.116	0.124
F		3.0			0.118	
F1		1.5			0.059	
G	0.2	0.3	0.4	0.008	0.012	0.016
H	0.58	0.78	0.98	0.023	0.031	0.039
J	4.3	4.5	4.7	0.169	0.177	0.185
K		0.88			0.035	

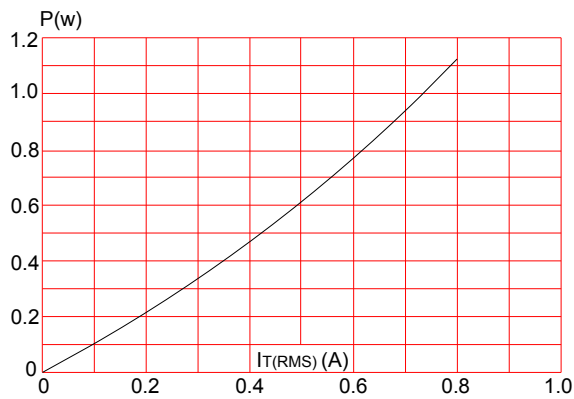
**FOOTPRINT-SOT-89-2L (dimensions in mm)**



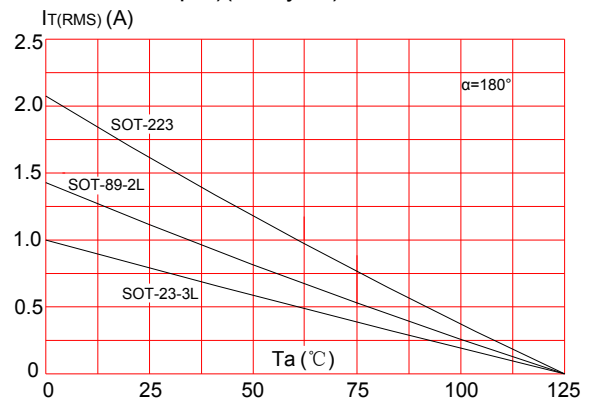
MARKING



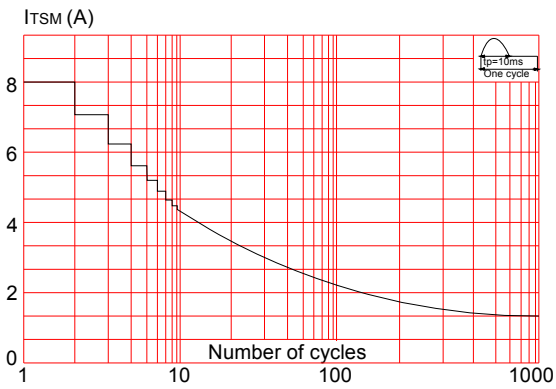
**FIG.1** Maximum power dissipation versus RMS on-state current



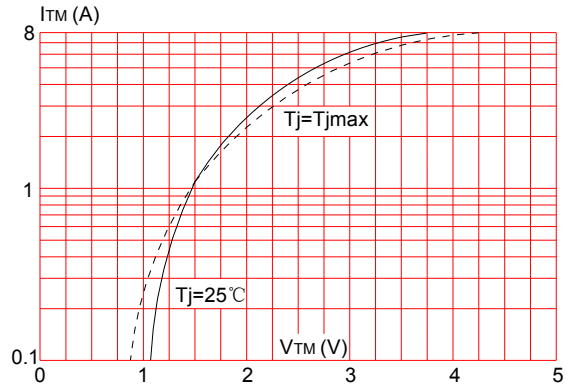
**FIG.2:** RMS on-state current versus ambient temperature (printed circuit board FR4, copper thickness:35 $\mu$ m)(full cycle)



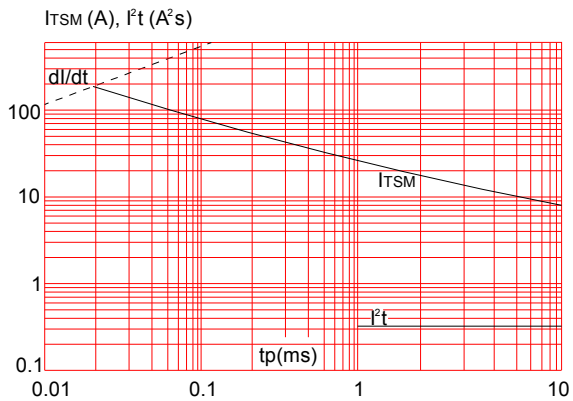
**FIG.3:** Surge peak on-state current versus number of cycles



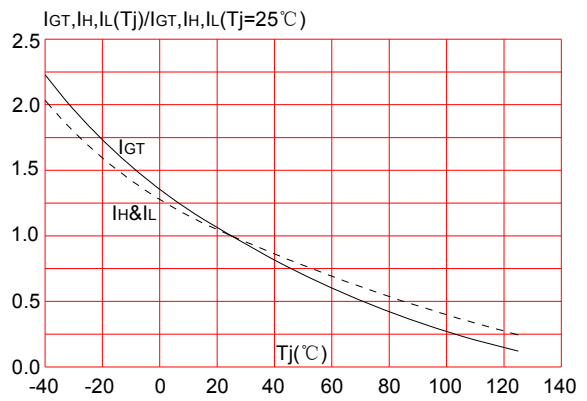
**FIG.4:** On-state characteristics (maximum values)



**FIG.5:** Non-repetitive surge peak on-state current for a sinusoidal pulse with width  $t_p < 10\text{ms}$ , and corresponding value of  $I^2t$  ( $dI/dt < 50\text{A}/\mu\text{s}$ )

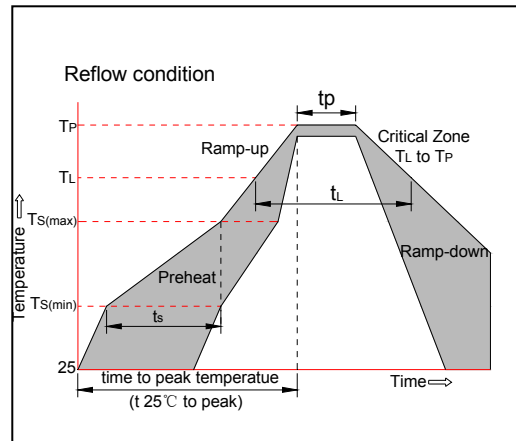


**FIG.6:** Relative variations of gate trigger current, holding current and latching current versus junction temperature




**SOLDERING PARAMETERS**

Reflow Condition		Pb-Free assembly (see figure at right)
Pre Heat	-Temperature Min ( $T_{s(min)}$ )	+150°C
	-Temperature Max ( $T_{s(max)}$ )	+200°C
	-Time (Min to Max) ( $t_s$ )	60-180 secs.
Average ramp up rate (Liquidus Temp ( $T_L$ ) to peak)		3°C/sec. Max
$T_{s(max)}$ to $T_L$ - Ramp-up Rate		3°C/sec. Max
Reflow	-Temperature( $T_L$ ) (Liquidus)	+217°C
	-Temperature( $t_L$ )	60-150 secs.
Peak Temp ( $T_p$ )		+260(+0/-5)°C
Time within 5°C of actual Peak Temp ( $t_p$ )		20-40secs.
Ramp-down Rate		6°C/sec. Max
Time 25°C to Peak Temp ( $T_P$ )		8 min. Max
Do not exceed		+260°C



Information furnished in this document is believed to be accurate and reliable. However, Jiangsu JieJie Microelectronics Co.,Ltd assumes no responsibility for the consequences of use without consideration for such information nor use beyond it. Information mentioned in this document is subject to change without notice, apart from that when an agreement is signed, Jiangsu JieJie complies with the agreement. Products and information provided in this document have no infringement of patents. Jiangsu JieJie assumes no responsibility for any infringement of other rights of third parties which may result from the use of such products and information. This document is the ninth version which is made in 1-Apr.-2019. This document supersedes and replaces all information previously supplied.

 is a registered trademark of Jiangsu JieJie Microelectronics Co.,Ltd.

Copyright ©2019 Jiangsu JieJie Microelectronics Co.,Ltd. Printed All rights reserved.