



JCD20SJ12ACT

SiC Schottky Diode

Rev.2.0

DESCRIPTION:

- ✧ 1200V Schottky rectifier
- ✧ Zero reverse recovery current
- ✧ Zero forward recovery voltage
- ✧ High frequency operation
- ✧ Switching characteristics independent of temperature
- ✧ Fast switch
- ✧ Positive temperature coefficient of forward voltage (V_F)

BENEFIT:

- ✧ Lower switching loss
- ✧ No thermal runaway in parallel devices
- ✧ Lower heatsink dependent

APPLICATION:

- ✧ HVAC
- ✧ Switch mode power supplies(SMPS)
- ✧ Boost diodes in PFC or DC/DC stages
- ✧ Free wheeling diodes in inverter stages
- ✧ AC/DC converters

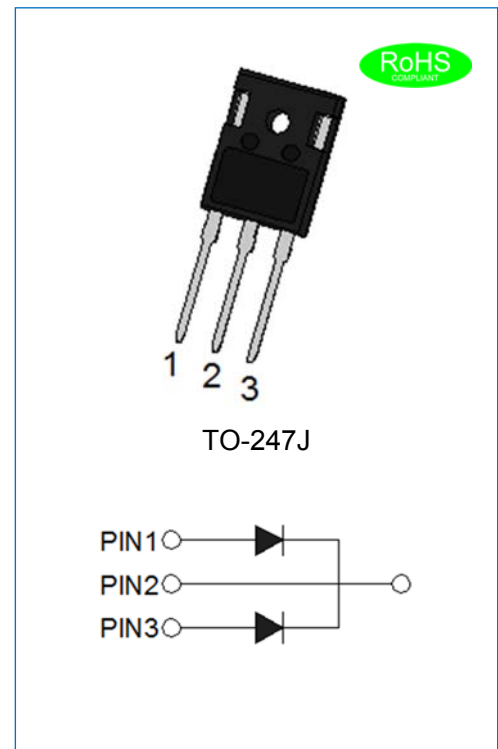

ABSOLUTE MAXIMUM RATING

(Rating at 25°C junction temperature unless otherwise specified.)

Parameter		Symbol	Value	Unit
Maximum repetitive peak reverse voltage		V_{RRM}	1200	V
Maximum DC blocking voltage		V_{DC}	1200	V
Continuous forward current	$T_C=150^{\circ}C$	I_F	10/20	A
Repetitive peak forward surge current	$t_p=10ms, T_C=25^{\circ}C$	I_{FRM}	50	A
Non-repetitive peak forward surge current	$t_p=10ms, T_C=25^{\circ}C$	I_{FSM}	80	A
Non-Repetitive peak forward surge current	$T_C=25^{\circ}C, t_p= 10\mu s,$ Pulse	I_{FMax}	600	A
Power dissipation	$T_C=25^{\circ}C$	P_{tot}	153	W
	$T_C=110^{\circ}C$		66	
Operating junction and storage temperature		T_j, T_{stg}	-55 to+175	$^{\circ}C$

ELECTRICAL CHARACTERISTICS

Parameter	Conditions	Symbol	Value			Unit
			Min.	Typ.	Max.	
Forward voltage	$I_F=10A, T_j=25^{\circ}C$	V_F	-	1.5	1.8	V
	$I_F=10A, T_j=175^{\circ}C$		-	2.2	3.0	
Reverse current	$V_R=1200V, T_j=25^{\circ}C$	I_R	-	2	5	μA
	$V_R=1200V, T_j=175^{\circ}C$		-	20	40	
Total capacitance	$V_R=0V, f=1MHz$	C	-	610	-	pF
	$V_R=400V, f=1MHz$		-	46	-	
	$V_R=800V, f=1MHz$		-	36	-	
Total capacitance charge	$V_R=800V, T_j=25^{\circ}C$	Q_C	-	50	-	nC
Capacitance stored energy	$V_R=800V$	E_C	-	25	-	μJ

THERMAL CHARACTERISTICS

Symbol	Parameter	Value	Unit
$R_{th(j-c)}$	Junction to Case	1.15	$^{\circ}C/W$

ORDERING INFORMATION

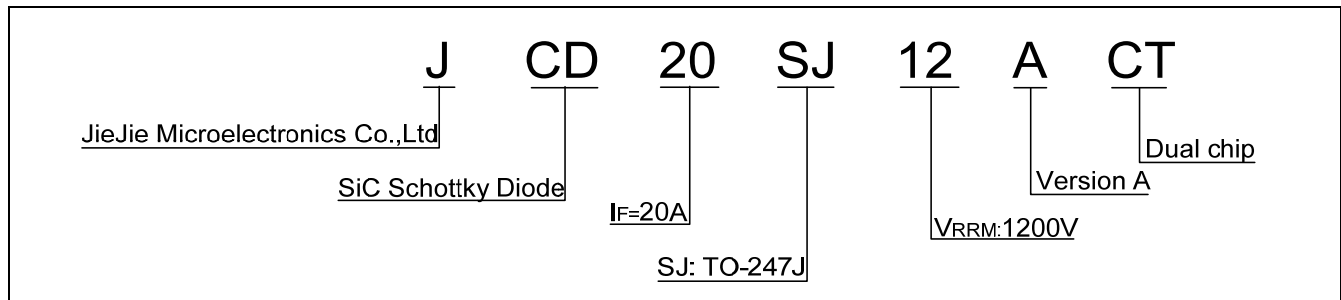

PACKAGE MECHANICAL DATA

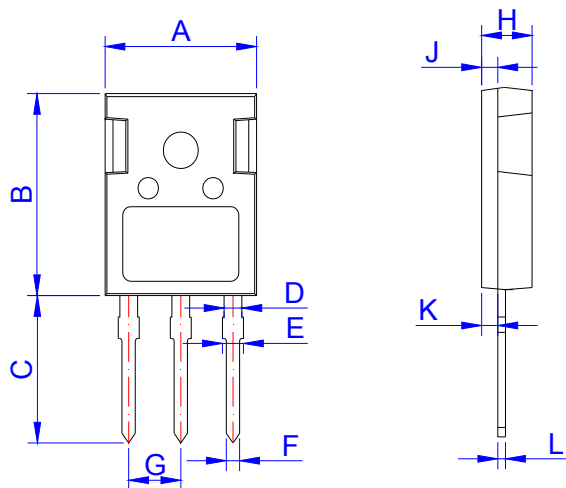

TO-247J

Ref.	Dimensions					
	Millimeters			Inches		
	Min.	Typ.	Max.	Min.	Typ.	Max.
A	15.50	15.80	16.10	0.610	0.622	0.634
B	20.80	21.00	22.20	0.819	0.828	0.874
C	19.70	20.00	20.30	0.776	0.787	0.799
D	1.80	2.00	2.20	0.071	0.079	0.087
E	1.90	2.10	2.30	0.075	0.083	0.091
F	1.00	1.20	1.40	0.039	0.047	0.055
G		5.44			0.214	
H	4.80	5.00	5.20	0.189	0.197	0.205
J	1.90	2.00	2.10	0.075	0.079	0.083
K	2.20	2.35	2.50	0.087	0.093	0.098
L	0.41	0.60	0.79	0.016	0.024	0.031

CHARACTERISTICS CURVE

FIG.1: Forward characteristics

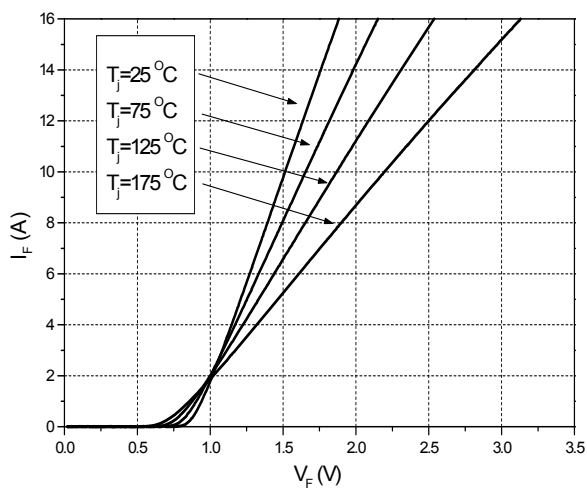

FIG.2: Reverse characteristics

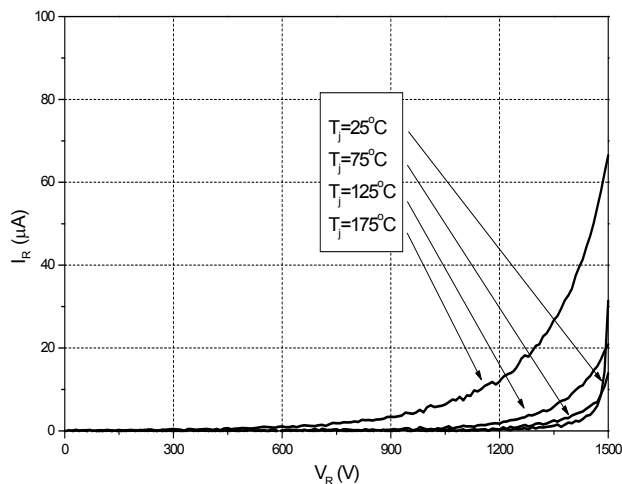

FIG.3: Capacitance vs. reverse voltage

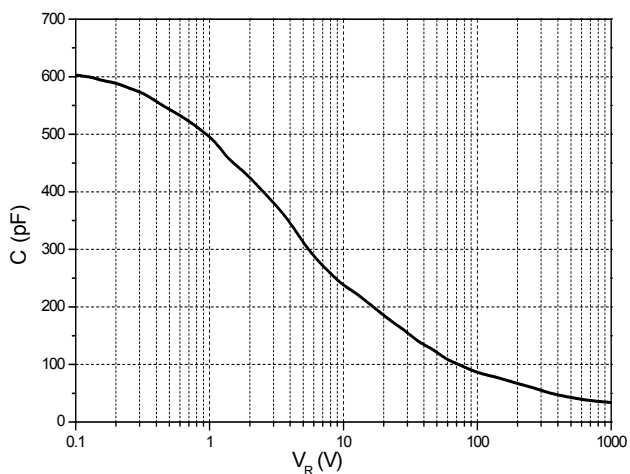
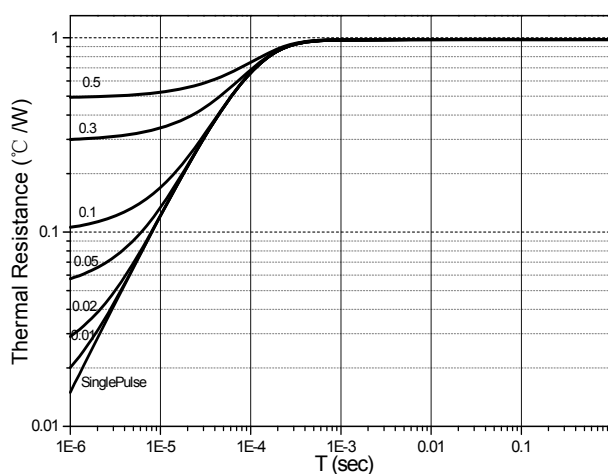

FIG.4: Transient thermal impedance



CHARACTERISTICS CURVE

FIG.5: Capacitance charge vs. reverse voltage

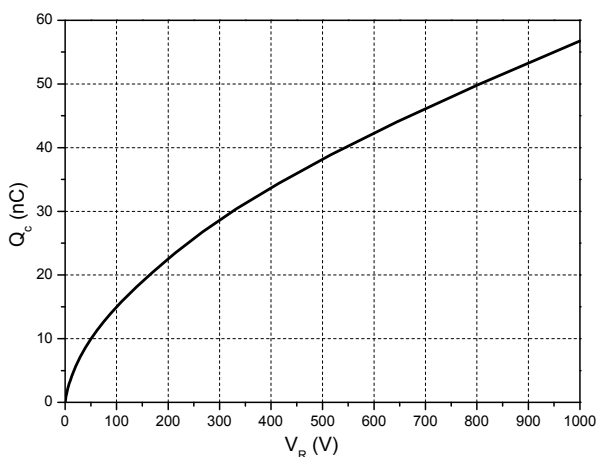

FIG.6: Capacitance stored energy

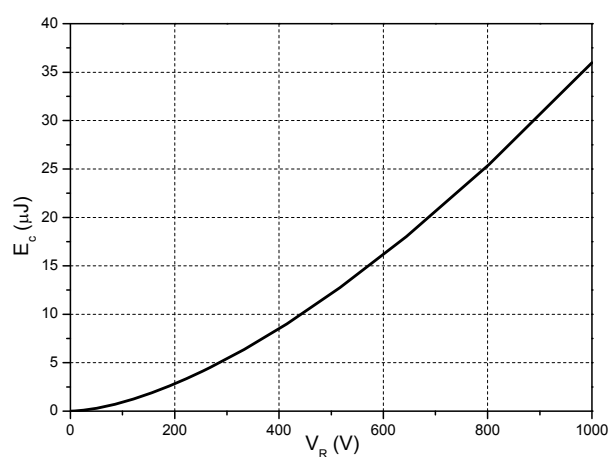

FIG.7: Power derating

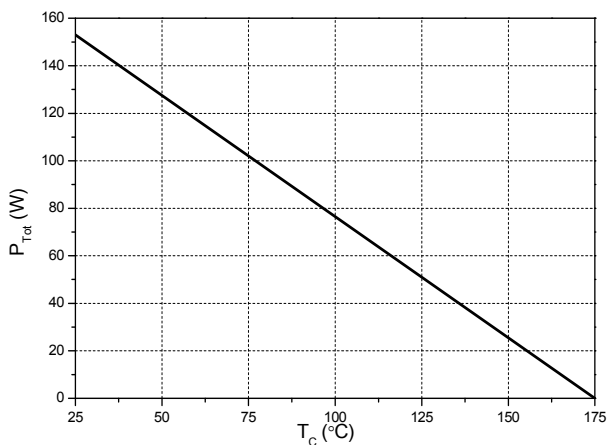
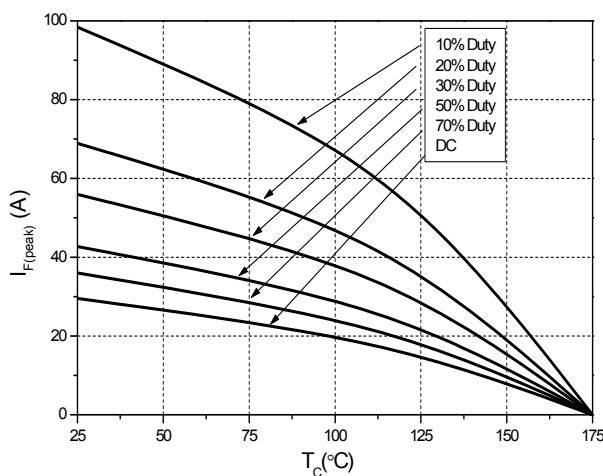

FIG.8: Current derating



Information furnished in this document is believed to be accurate and reliable. However, Jiangsu JieJie Microelectronics Co.,Ltd assumes no responsibility for the consequences of use without consideration for such information nor use beyond it.

Information mentioned in this document is subject to change without notice, apart from that when an agreement is signed, Jiangsu JieJie complies with the agreement.

Products and information provided in this document have no infringement of patents. Jiangsu JieJie assumes no responsibility for any infringement of other rights of third parties which may result from the use of such products and information.

This document is the second version which is made in 4-Aug.-2020. This document supersedes and replaces all information previously supplied.



is a registered trademark of Jiangsu JieJie Microelectronics Co.,Ltd.

Copyright ©2020 Jiangsu JieJie Microelectronics Co.,Ltd. Printed All rights reserved.