



## JEFR0808FPL

### EPI FAST SOFT RECOVERY RECTIFIER

Rev.1.1

#### DESCRIPTION

- ✧ Plastic package has underwriters laboratory flammability classification 94V-0
- ✧ Lead free in comply with EU RoHS 2011/65/EU directives
- ✧ Low reverse leakage current
- ✧ Fast recovery time and soft recovery characteristics
- ✧ Low recovery loss
- ✧ Applications for discontinuous current mode (DCM) power factor correction (PFC), High frequency switched-mode power supplies, and TV power supplies

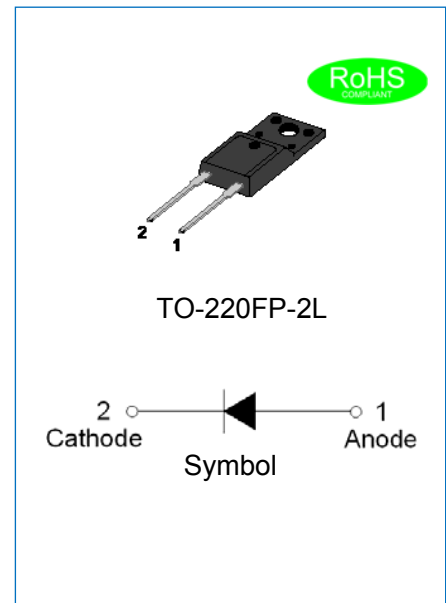

#### MECHANICAL DATA

- ✧ Case: TO-220FP-2L molded plastic over passivated junction
- ✧ Terminals: Solder plated, solderable per J-STD-002
- ✧ Weight: 2 gram

#### ABSOLUTE MAXIMUM RATING (Rating at 25°C case temperature unless otherwise specified.)

Parameter	Symbol	JEFR0808FPL	Unit
Maximum repetitive peak reverse voltage	$V_{RRM}$	800	V
Maximum RMS voltage	$V_{RMS}$	560	V
Maximum DC blocking voltage	$V_{DC}$	800	V
Maximum average forward current $\delta=0.5, T_C=100^\circ\text{C}$	$I_{F(AV)}$	8	A
Peak forward surge current: 8.3ms single half sine-wave superimposed on rated load	$I_{FSM}$	125	A
Junction temperature and storage temperature range	$T_j, T_{stg}$	-55 to +175	°C

#### ISOLATION CHARACTERISTICS

Symbol	Parameter	Conditions	Min.	Typ.	Max.	Unit
$V_{isol(RMS)}$	RMS isolation voltage	50 Hz ≤ f ≤ 60 Hz; RH ≤ 65 %; from all pins to external heatsink; sinusoidal waveform; clean and dust free	-	-	2500	V
$C_{isol}$	Isolation capacitance	from cathode to external heatsink	-	10	-	pF

**ELECTRICAL CHARACTERISTICS**(Rating at 25°C case temperature unless otherwise specified.)

Parameter		Symbol	Min.	Typ.	Max.	Unit
Forward voltage @ $I_F=8A$	$T_j=25^{\circ}C$	$V_F$	-	-	1.7	V
	$T_j=150^{\circ}C$		-	-	1.5	
DC reverse current at rated DC blocking voltage	$T_j=25^{\circ}C$	$I_R$	-	-	5	$\mu A$
	$T_j=150^{\circ}C$		-	-	200	
Reverse recovery time	$I_F=0.5A, I_R=1A, I_{rr}=0.25A$	$t_{rr}$	-	-	75	ns

**THERMAL RESISTANCES**

Symbol	Parameter	Min.	Typ.	Max.	Unit
$R_{th(j-c)}$	Thermal resistance from junction to case	-	2	-	$^{\circ}C/W$

**MARKING**

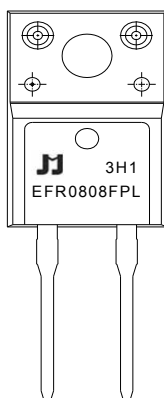

EFR	EPI Fast Recovery Rectifier
08	$I_{F(AV)}=8A$
08	$V_{RRM}:800V$
FPL	Package:TO-220FP-2L

$xH1$ : Month, 1、2、3 ~ 9、A、B、C

$3x1$ :

2018	2019	2020	2021	2022	2023	2024
H	I	J	K	L	M	N
2025	2026	2027	2028	2029	2030	...
O	P	Q	R	S	T	...

$3Hx$ : Batch number

**ORDERING INFORMATION**

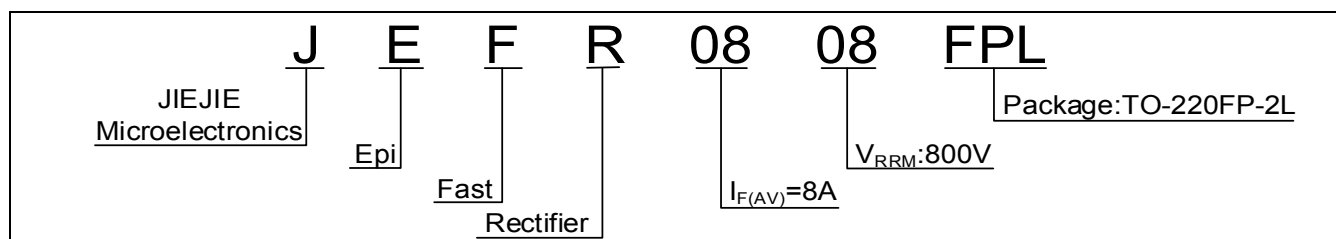

**PACKAGE MECHANICAL DATA**

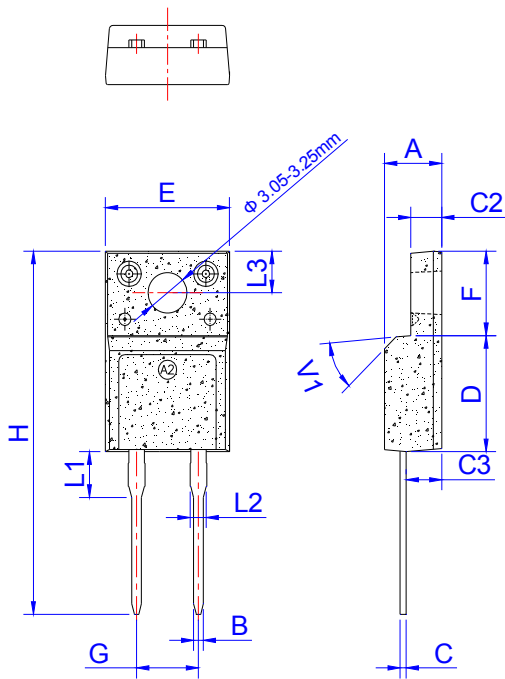

Ref.	Dimensions					
	Millimeters			Inches		
	Min.	Typ.	Max.	Min.	Typ.	Max.
A	4.50		4.90	0.177		0.193
B	0.74	0.80	0.83	0.029	0.031	0.033
C	0.47		0.65	0.019		0.026
C2	2.45		2.75	0.096		0.108
C3	2.60		3.00	0.102		0.118
D	8.80		9.30	0.346		0.366
E	9.80		10.4	0.386		0.410
F	6.40		6.80	0.252		0.268
G		5.08			0.200	
H	28.0		29.8	1.102		1.173
L1		3.63			0.143	
L2	1.14		1.70	0.045		0.067
L3		3.30			0.130	
V1		45°			45°	

**PACKAGE INFORMATION-TO-220FP-2L**

OUTLINE	UNIT WEIGHT (g/PCS) typ.	TUBE (PCS)	PER CARTON (PCS)
TUBE	2	50	5,000

CHARACTERISTICS CURVE

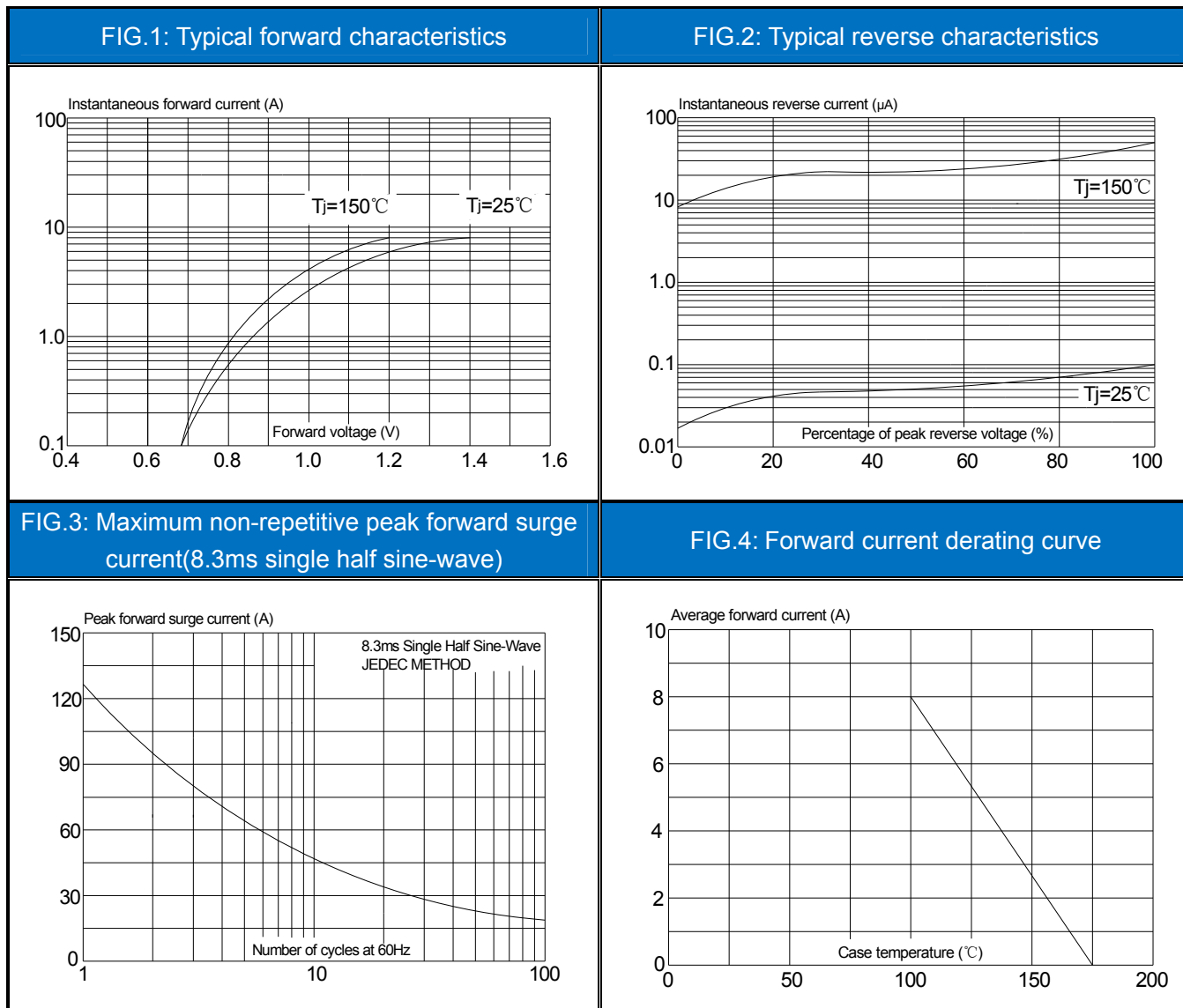

Information furnished in this document is believed to be accurate and reliable. However, Jiangsu JieJie Microelectronics Co.,Ltd assumes no responsibility for the consequences of use without consideration for such information nor use beyond it.

Information mentioned in this document is subject to change without notice, apart from that when an agreement is signed, Jiangsu JieJie complies with the agreement.

Products and information provided in this document have no infringement of patents. Jiangsu JieJie assumes no responsibility for any infringement of other rights of third parties which may result from the use of such products and information.

This document is the 1.1st version which is made in 29-July-2021. This document supersedes and replaces all information previously supplied.

 is a registered trademark of Jiangsu JieJie Microelectronics Co.,Ltd.

Copyright ©2021 Jiangsu JieJie Microelectronics Co.,Ltd. Printed All rights reserve.