



JECR1506FPL EPI HYPERFAST SOFT RECOVERY RECTIFIER

Rev.1.1

DESCRIPTION

- ✧ Plastic package has underwriters laboratory flammability classification 94V-0
- ✧ Lead free in comply with EU RoHS 2011/65/EU directives
- ✧ Low reverse leakage current
- ✧ Hyperfast recovery time and soft recovery characteristics
- ✧ Low recovery loss
- ✧ Applications for continuous current mode (CCM) power factor correction (PFC), active PFC in air conditioner, high frequency switched-mode power supplies

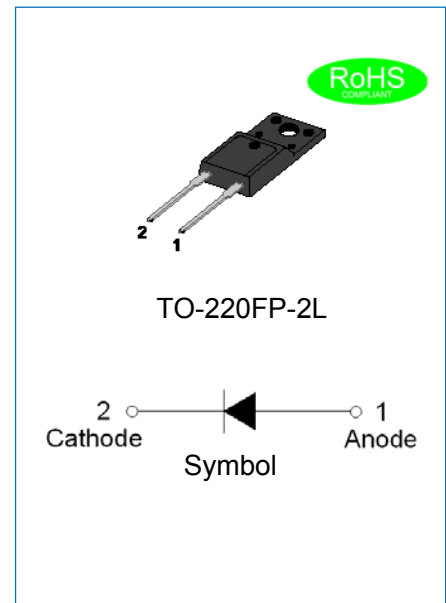

MECHANICAL DATA

- ✧ Case: TO-220FP-2L molded plastic over passivated junction
- ✧ Terminals: Solder plated, solderable per J-STD-002
- ✧ Weight: 2 gram

ABSOLUTE MAXIMUM RATING (Rating at 25°C case temperature unless otherwise specified.)

Parameter	Symbol	JECR1506FPL	Unit
Maximum repetitive peak reverse voltage	V_{RRM}	600	V
Maximum RMS voltage	V_{RMS}	420	V
Maximum DC blocking voltage	V_{DC}	600	V
Maximum average forward current $\delta=0.5, T_h \leq 61^\circ\text{C}$, square-wave pulse	$I_{F(AV)}$	15	A
Peak forward surge current: 10ms single half sine-wave superimposed on rated load	I_{FSM}	180	A
Peak forward surge current: 8.3ms single half sine-wave superimposed on rated load		200	
Junction temperature and storage temperature range	T_j, T_{stg}	-55 to +175	°C

ISOLATION CHARACTERISTICS

Symbol	Parameter	Conditions	Min.	Typ.	Max.	Unit
$V_{isol(RMS)}$	RMS isolation voltage	50Hz≤f≤60Hz;RH≤65%; from all pins to external heatsink; sinusoidal waveform; clean and dust free	-	-	2500	V
C_{isol}	Isolation capacitance	from cathode to external heatsink	-	10	-	pF

ELECTRICAL CHARACTERISTICS(Rating at 25°C case temperature unless otherwise specified.)

Parameter		Symbol	Min.	Typ.	Max.	Unit
Forward voltage	$I_F=15A, T_j=25^\circ C$	V_F	-	2.7	3.2	V
	$I_F=15A, T_j=150^\circ C$		-	1.4	2	
Maximum DC reverse current at rated DC blocking voltage	$T_j=25^\circ C$	I_R	-	-	5	μA
	$T_j=150^\circ C$		-	-	300	
Reverse recovery time	$I_F=1A, V_R=30V,$ $di/dt=200A/\mu s, T_j=25^\circ C$	t_{rr}	-	13	18	ns
	$I_F=15A, V_R=400V,$ $di/dt=500A/\mu s, T_j=25^\circ C$		-	22	-	
	$I_F=15A, V_R=200V,$ $di/dt=200A/\mu s, T_j=25^\circ C$		-	28	-	
	$I_F=15A, V_R=200V,$ $di/dt=200A/\mu s, T_j=125^\circ C$		-	39	-	
Peak reverse recovery current	$I_F=15A, V_R=200V,$ $di/dt=200A/\mu s, T_j=25^\circ C$	I_{RM}	-	2.1	-	A
	$I_F=15A, V_R=200V,$ $di/dt=200A/\mu s, T_j=125^\circ C$		-	5.8	-	
Recovered charge	$I_F=15A, V_R=200V,$ $di/dt=200A/\mu s, T_j=25^\circ C$	Q_r	-	30	-	nC
	$I_F=15A, V_R=100V,$ $di/dt=200A/\mu s, T_j=25^\circ C$		-	115	-	

THERMAL RESISTANCES

Symbol	Parameter	Min.	Typ.	Max.	Unit
$R_{th(j-h)}$	Thermal resistance from junction to heatsink	-	-	4.5	$^\circ C/W$
$R_{th(j-a)}$	Thermal resistance from junction to ambient	-	55	-	$^\circ C/W$

MARKING

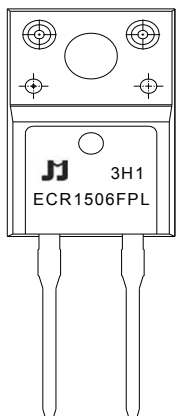

ECR	EPI Hyperfast Recovery Rectifier
15	$I_{F(AV)}=15A$
06	$V_{RRM}:600V$
FPL	Package:TO-220FP-2L

$xH1$: Month, 1、2、3 ~ 9、A、B、C

$3x1$:

2018	2019	2020	2021	2022	2023	2024
H	I	J	K	L	M	N
2025	2026	2027	2028	2029	2030	...
O	P	Q	R	S	T	...

$3Hx$: Batch number

ORDERING INFORMATION

J	E	C	R	15	06	FPL	Package: TO-220FP-2L
JIEJIE Microelectronics	Epi Hyperfast	Rectifier		$I_{F(AV)}=15A$	$V_{RRM}:600V$		

PACKAGE MECHANICAL DATA

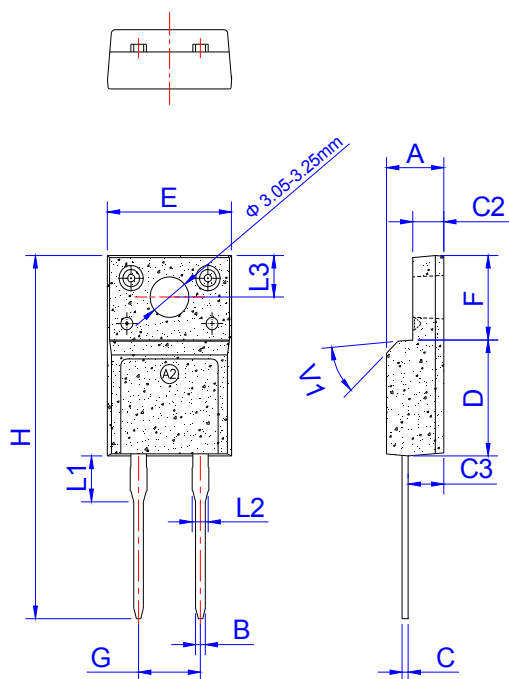

Ref.	Dimensions					
	Millimeters			Inches		
	Min.	Typ.	Max.	Min.	Typ.	Max.
A	4.50		4.90	0.177		0.193
B	0.74	0.80	0.83	0.029	0.031	0.033
C	0.47		0.65	0.019		0.026
C2	2.45		2.75	0.096		0.108
C3	2.60		3.00	0.102		0.118
D	8.80		9.30	0.346		0.366
E	9.80		10.4	0.386		0.410
F	6.40		6.80	0.252		0.268
G		5.08			0.200	
H	28.0		29.8	1.102		1.173
L1		3.63			0.143	
L2	1.14		1.70	0.045		0.067
L3		3.30			0.130	
V1		45°			45°	

PACKAGE INFORMATION-TO-220FP-2L

OUTLINE	UNIT WEIGHT (g/PCS) typ.	TUBE (PCS)	PER CARTON (PCS)
TUBE	2	50	5,000

CHARACTERISTICS CURVE

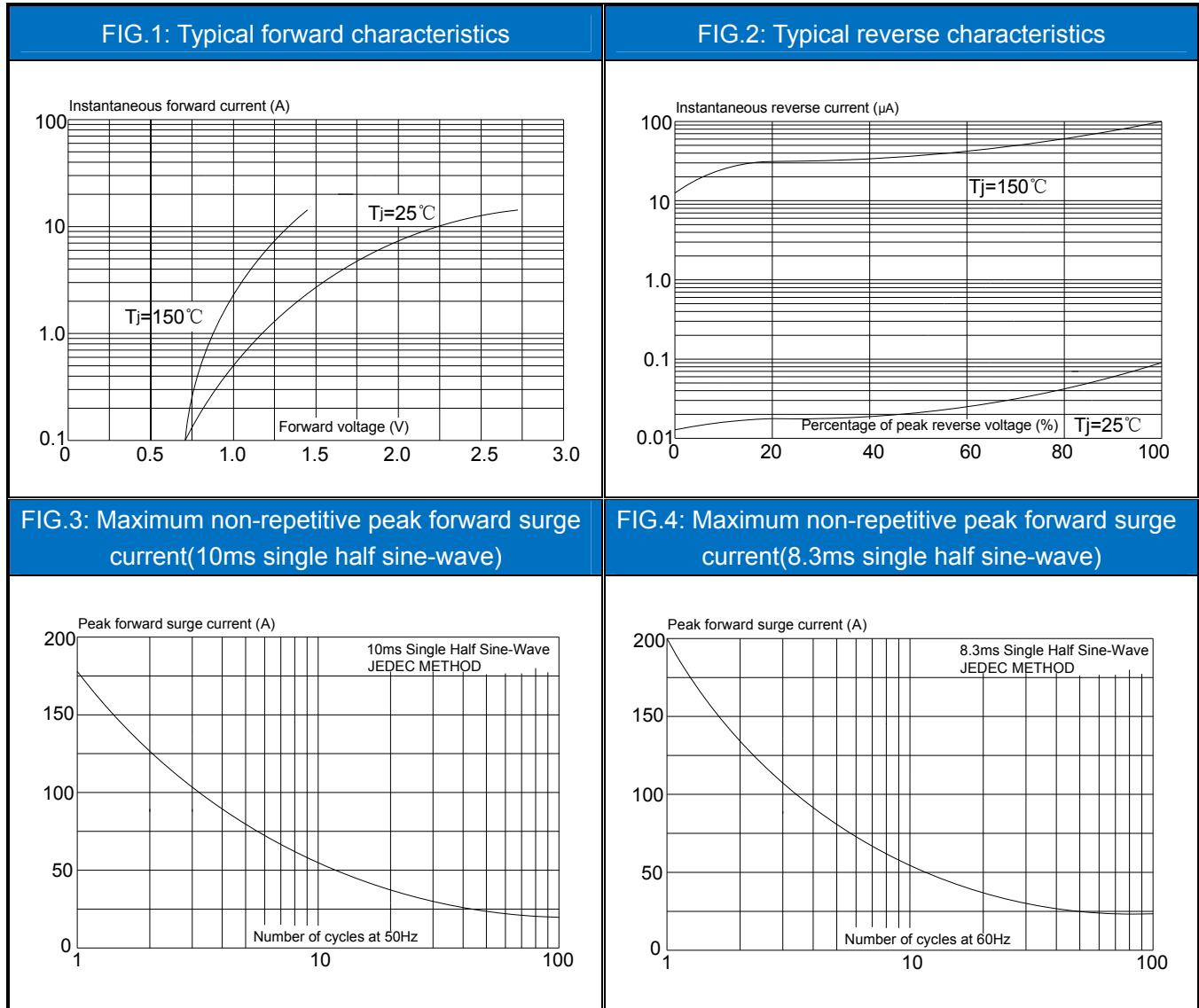

FIG.5: Forward current derating curve

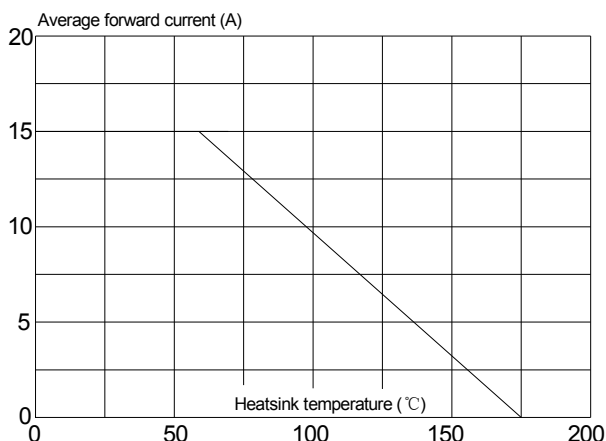
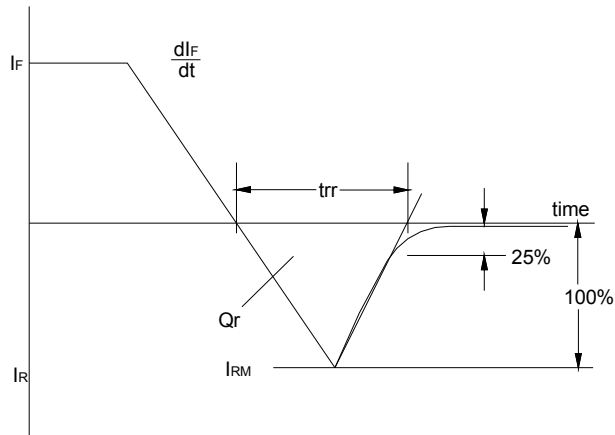

FIG.6: Reverse recovery definitions



Information furnished in this document is believed to be accurate and reliable. However, Jiangsu JieJie Microelectronics Co.,Ltd assumes no responsibility for the consequences of use without consideration for such information nor use beyond it.

Information mentioned in this document is subject to change without notice, apart from that when an agreement is signed, Jiangsu JieJie complies with the agreement.

Products and information provided in this document have no infringement of patents. Jiangsu JieJie assumes no responsibility for any infringement of other rights of third parties which may result from the use of such products and information.

This document is the 1.1st version which is made in 28-July-2021. This document supersedes and replaces all information previously supplied.

 is a registered trademark of Jiangsu JieJie Microelectronics Co.,Ltd.

Copyright ©2021 Jiangsu JieJie Microelectronics Co.,Ltd. Printed All rights reserve.