



SMF3.3A 200W Transient Voltage Suppressor

Rev.1.2

FEATURES:

- ✧ Planar technology.
- ✧ Halogen-free and RoHS compliant.
- ✧ Stand-off voltage: 3.3V.
- ✧ 200W peak pulse power capability at 10/1000μs waveform.
- ✧ Meets MSL level 1, per J-STD-020, LF maximum peak of 260°C.
- ✧ Terminal: solder plated, solderable per J-STD-002.
- ✧ Excellent clamping capability.
- ✧ Fast response time.
- ✧ IEC61000-4-2 (ESD) ±30kV (air), ±30kV (contact).

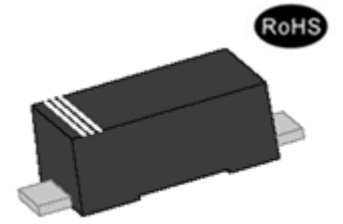

SOD-123FL

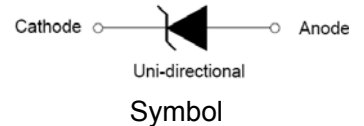

ABSOLUTE MAXIMUM RATINGS($T_A=25^{\circ}\text{C}$, RH=45%-75%, unless otherwise noted)

Parameter	Symbol	Value	Unit
Storage and operating junction temperature range	T_{STG}/T_J	-55 to +150	$^{\circ}\text{C}$
Peak pulse power dissipation at 10/1000μs waveform	P_{PP}	200	W
Typical thermal resistance junction to lead	$R_{\theta JL}$	100	$^{\circ}\text{C}/\text{W}$
Typical thermal resistance junction to ambient	$R_{\theta JA}$	220	$^{\circ}\text{C}/\text{W}$

MARKING

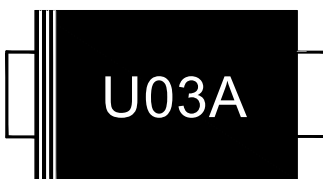

U03A : Device Marking Code

ELECTRICAL CHARACTERISTICS($T_A=25^{\circ}\text{C}$)

Part Number	V_R	$I_R@V_R$	$V_{BR}@I_T$	I_T	$V_C@I_{PP}$	$I_{PP}^{①}$	$C_o^{②}$	Marking
	V	μA(max)	V(min)	mA	V(max)	A(max)	pF(typ.)	
SMF3.3A	3.3	50	4.1	1	7.3	27	1900	U03A

① Surge waveform: 10/1000μs

② C_o is measured at: $V_{bias}=0\text{V}$, $V_{RMS}=0.1\text{V}$, $f=1\text{MHz}$

ORDERING INFORMATION

<div style="display: flex; justify-content: space-around;"> <div style="text-align: center;"> <p>SMF</p> <p>200W SOD-123FL Series</p> </div> <div style="text-align: center;"> <p>3.3</p> <p>V_R Voltage</p> </div> <div style="text-align: center;"> <p>A</p> <p>5% V_{BR} voltage tolerance</p> </div> </div>
--

RATINGS AND V-I CHARACTERISTICS CURVES ($T_A=25^{\circ}C$, unless otherwise noted)

FIG.1: V- I curve characteristics (Uni-directional)

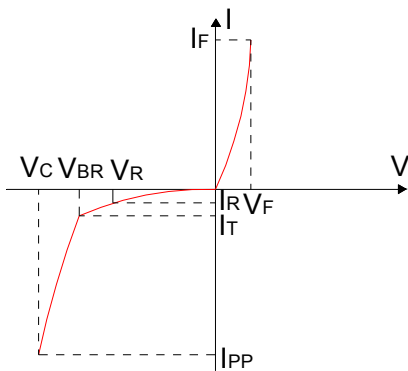

FIG.2: Pulse waveform

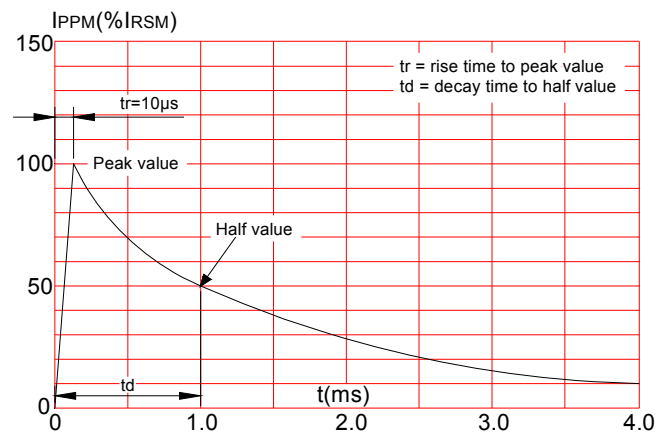
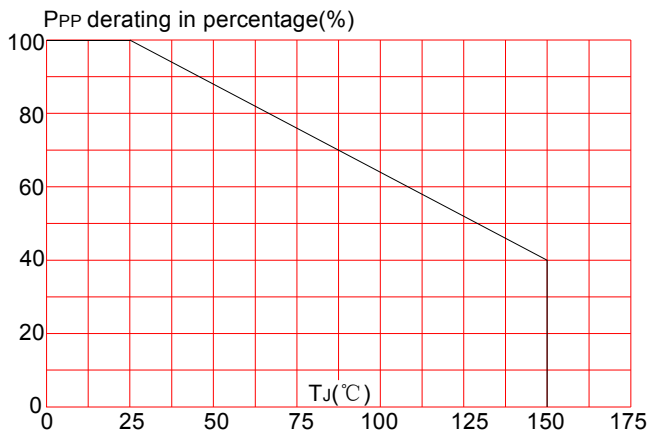
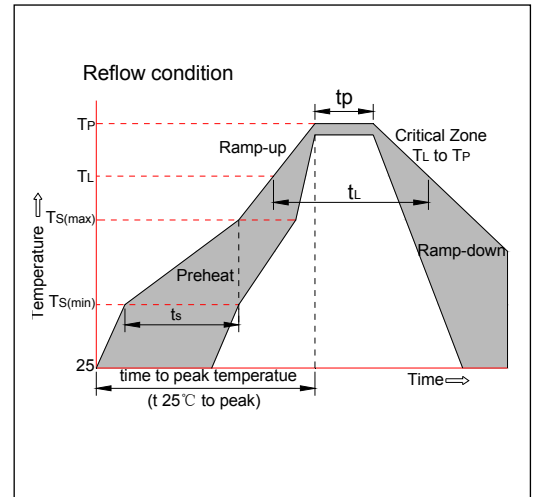

FIG.3: Pulse derating curve



SOLDERING PARAMETERS

Reflow Condition		Pb-Free assembly (see figure at right)
Pre Heat	-Temperature Min ($T_{s(min)}$)	+150°C
	-Temperature Max($T_{s(max)}$)	+200°C
	-Time (Min to Max) (ts)	60-180 secs.
Average ramp up rate (Liquidus Temp (T_L)to peak)		3°C/sec. Max
$T_{s(max)}$ to T_L - Ramp-up Rate		3°C/sec. Max
Reflow	-Temperature(T_L)(Liquidus)	+217°C
	-Temperature(t_L)	60-150 secs.
Peak Temp (T_p)		+260(+0/-5)°C
Time within 5°C of actual Peak Temp (t_p)		20-40secs.
Ramp-down Rate		6°C/sec. Max
Time 25°C to Peak Temp (T_p)		8 min. Max
Do not exceed		+260°C



PACKAGE MECHANICAL DATA

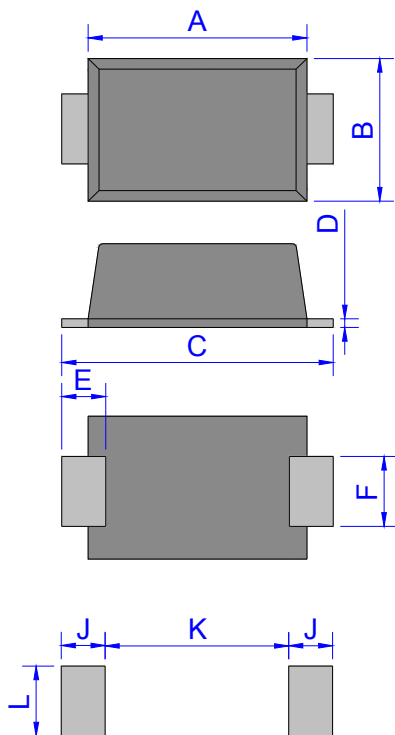

SOD-123FL

Ref.	Dimensions			
	Millimeters		Inches	
	Min.	Max.	Min.	Max.
A	2.60	3.00	0.102	0.118
B	1.60	2.00	0.063	0.079
C	3.45	3.95	0.136	0.156
D	0.10	0.25	0.004	0.01
E	0.3	0.9	0.012	0.035
F	0.80	1.20	0.031	0.047
G	0.95	1.35	0.037	0.053
J	1.30		0.051	
K		1.70		0.067
L	1.30		0.051	

TAPE AND REEL SPECIFICATION-SOD-123FL

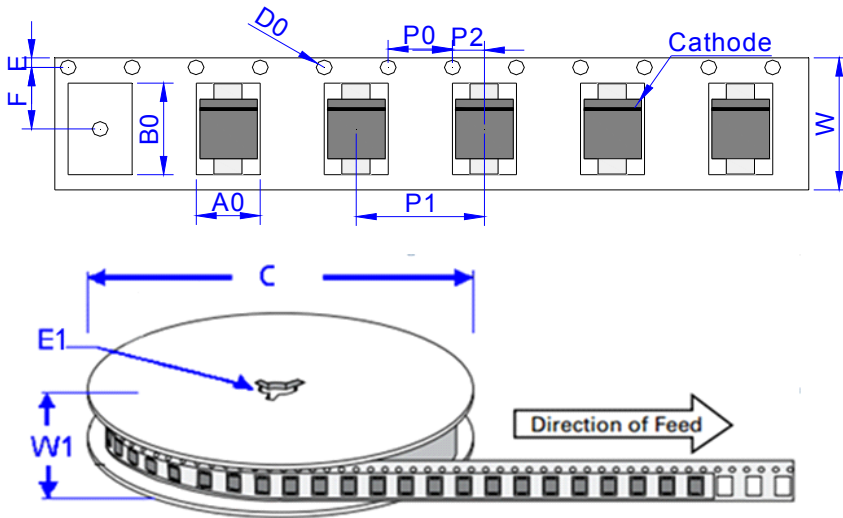

Ref.	Dimensions	
	Millimeters	Inches
A0	1.95 ± 0.3	0.077± 0.012
B0	3.95 ± 0.3	0.156 ± 0.012
C	178	7.0
D0	1.55 ± 0.1	0.061 ± 0.004
E	1.75 ± 0.2	0.069 ± 0.008
E1	13.3 ± 0.3	0.524± 0.012
F	3.50 ± 0.2	0.138 ± 0.008
P0	4.00 ± 0.2	0.157 ± 0.008
P1	4.00 ± 0.2	0.157 ± 0.008
P2	2.00 ± 0.2	0.079 ± 0.008
W	8.0± 0.2	0.315 ± 0.008
W1	11.5 ± 1.0	0.453 ± 0.039

PART No.	UNIT WEIGHT (g/PCS) typ.	REEL (PCS)	PER CARTON (PCS)	DESCRIPTION
SMF3.3A	0.0136	3000	150,000	7 inch reel pack

Information furnished in this document is believed to be accurate and reliable. However, Jiangsu JieJie Microelectronics Co.,Ltd assumes no responsibility for the consequences of use without consideration for such information nor use beyond it.

Information mentioned in this document is subject to change without notice, apart from that when an agreement is signed, Jiangsu JieJie complies with the agreement.

Products and information provided in this document have no infringement of patents. Jiangsu JieJie assumes no responsibility for any infringement of other rights of third parties which may result from the use of such products and information.

This document is the 1.2nd version which is made in 2-Aug.-2021. This document supersedes and replaces all information previously supplied.

 is a registered trademark of Jiangsu JieJie Microelectronics Co.,Ltd.

Copyright©2021 Jiangsu JieJie Microelectronics Co.,Ltd. Printed All rights reserved.